



## **ADDENDUM NO. 2**

June 1, 2010

### ***JACK BROOKS REGIONAL AIRPORT WEST DITCH IMPROVEMENTS***

***Jefferson County, Texas***

**Job No. JEF-120, CONTRACT NO. 1**

---

This document constitutes ADDENDUM NO. 2 to the JACK BROOKS REGIONAL AIRPORT WEST DITCH IMPROVEMENTS PROJECT issued for bidding by Jefferson County, Texas. **BIDDER MUST ACKNOWLEDGE RECEIPT OF THIS ADDENDUM ON HIS BID FORM.**

#### **CONTRACT DOCUMENTS**

1. **REPLACE "SECTION C" STANDARD FORM OF AGREEMENT** with the **REVISED "SECTION C" STANDARD FORM OF AGREEMENT** (attached). Changes included are the addition and deletion of **BASE BID PAY ITEMS** and **CHANGES TO QUANTITIES**.
2. **DELETE SPECIAL PROVISION NO. 1 TO ITEM NO. P-151.**
3. **REPLACE SPECIAL PROVISION NO. 1 TO ITEM NO. T-901** with the **REVISED SPECIAL PROVISION NO. 1 TO ITEM NO. T-901** (attached). Changes include the addition of **"Bermuda grass at a rate of 2.7 lbs. PLS/ac."**
4. **ADD** to the project specifications. **GEOTECHNICAL REPORT NO. 78-216** (for informational purposes only) prepared by McBride – Ratcliff & Associates, Inc.



CONSTRUCTION PLANS

1. **REPLACE** the following **PLAN SHEETS** with the attached **REVISED PLAN SHEETS**.

**PLAN SHEETS – 2, 4, 5, 6, 7, 28, 29, 30, AND 31**

2. **DELETE** the following **PLANS SHEETS**:

**PLAN SHEETS – 34, 35, 36, AND 37**

3. **ADD** the following **PLAN SHEETS**:

**PLAN SHEETS – 7A AND 7B**

***NO OTHER CONDITIONS OF THE CONTRACT ARE HEREBY CHANGED***

[END OF ADDENDUM NO. 2]

**EJCDC  
STANDARD FORM OF AGREEMENT  
BETWEEN OWNER AND CONTRACTOR  
ON THE BASIS OF A STIPULATED PRICE**

**THIS AGREEMENT** is by and between \_\_\_\_\_ JEFFERSON COUNTY \_\_\_\_\_

(hereinafter called OWNER) and \_\_\_\_\_

(hereinafter called CONTRACTOR).

OWNER and CONTRACTOR, in consideration of the mutual covenants hereinafter set forth, agree as follows:

**ARTICLE 1 - WORK**

1.01 CONTRACTOR shall complete all Work as specified or indicated in the Contract Documents. The Work is generally described as follows:

*The construction of Airport West ditch improvements for the Jack Brooks Regional Airport.*

**ARTICLE 2 - THE PROJECT**

2.01 The Project for which the Work under the Contract Documents may be the whole or only a part is generally described as follows:

**JACK BROOKS REGIONAL IMPROVEMENTS TO AIRPORT WEST DITCH.**

**ARTICLE 3 - ENGINEER**

3.01 The Project has been designed by **Arceneaux & Gates Consulting Engineers, Inc.** who is hereinafter called ENGINEER and who is to act as OWNER's representative, assume all duties and responsibilities, and have the rights and authority assigned to ENGINEER in the Contract Documents in connection with the completion of the Work in accordance with the Contract Documents.

**ARTICLE 4 - CONTRACT TIMES**

4.01 *Time of the Essence*

4.02 *Days to Achieve Substantial Completion and Final Payment*

A. The Work will be substantially completed within **150 WORKING DAYS** after the date when the Contract Times commence to run as provided in paragraph 2.03 of the General Conditions, and completed and ready for final payment in accordance with paragraph 14.07 of the General Conditions.

4.03 *Liquidated Damages*

A. CONTRACTOR and OWNER recognize that time is of the essence of this Agreement and that OWNER will suffer financial loss if the Work is not completed within the times specified in paragraph 4.02 above, plus any extensions thereof allowed in accordance with Article 12 of the General Conditions. The parties also recognize the delays, expense, and difficulties involved in proving in a legal or arbitration proceeding the actual loss suffered by OWNER if the Work is not completed on time. Accordingly, instead of requiring any such proof, OWNER and CONTRACTOR agree that as liquidated damages for delay (but

not as a penalty), **CONTRACTOR SHALL PAY OWNER \$500** for each day that expires after the time specified in paragraph 4.02 for Substantial Completion until the Work is substantially complete.

**ARTICLE 5 - CONTRACT PRICE**

5.01 OWNER shall pay CONTRACTOR for completion of the Work in accordance with the Contract Documents an amount in current funds equal to the sum of the amounts determined pursuant to paragraphs 5.01.A, below:

A. For all Unit Price Work, an amount equal to the sum of the established unit price for each separately identified item of Unit Price Work times the estimated quantity of that item as indicated in this paragraph 5.01.A:

**UNIT PRICE WORK**

| <b>Item No.</b> | <b>Approx. Qty.</b> | <b>Unit</b> | <b>Description of Item with Unit Price Written in Words</b>  | <b>Unit Price</b> | <b>Amount</b> |
|-----------------|---------------------|-------------|--|-------------------|---------------|
| 1.              | 1                   | L.S.        | Mobilization, Including Bonds, Insurance, Outside Facilities, Complete.<br>@ _____<br>_____<br>Per Lump Sum          | \$ _____          | \$ _____      |
| 2.              | 36                  | AC.         | Clearing and Grubbing, Alignment "A" Sta. 0+00 to Sta. 97+19, Complete in Place.<br>@ _____<br>_____<br>Per Acre     | \$ _____          | \$ _____      |
| 3.              | 54,981              | C.Y.        | Drainage Excavation, Alignment "A" Sta. 0+60 to Sta. 96+93, Complete in Place.<br>@ _____<br>_____<br>Per Cubic Yard | \$ _____          | \$ _____      |
| 4.              | 16,695              | C.Y.        | Embankment in Place, Alignment "A" Sta. 0+60 to Sta. 96+93, Complete in Place.<br>@ _____<br>_____<br>Per Cubic Yard | \$ _____          | \$ _____      |
| 5.              | 100                 | C.Y.        | Drainage Excavation, Alignment "C" Sta. 0+00 to Sta. 29+56, Complete in Place.<br>@ _____<br>_____<br>Per Cubic Yard | \$ _____          | \$ _____      |

| Item No. | Approx. Qty. | Unit | Description of Item with Unit Price Written in Words  | Unit Price | Amount   |
|----------|--------------|------|---|------------|----------|
| 6.       | 11,715       | C.Y. | Embankment in Place, Alignment "C" Sta. 0+00 to Sta. 29+56, Complete in Place.<br>@ _____<br>Per Cubic Yard                             | \$ _____   | \$ _____ |
| 7.       | 60           | L.F. | 12' x 6' Reinforced Concrete Box, C-1433 with required Bedding and Backfill, Complete in Place.<br>@ _____<br>Per Linear Foot           | \$ _____   | \$ _____ |
| 8.       | 30           | L.F. | 12' x 5' Reinforced Concrete Box, C-1433 with required Bedding and Backfill, Complete in Place.<br>@ _____<br>Per Linear Foot           | \$ _____   | \$ _____ |
| 9.       | 30           | L.F. | 8' x 5' Reinforced Concrete Box, C-1433 with required Bedding and Backfill, Complete in Place.<br>@ _____<br>Per Linear Foot            | \$ _____   | \$ _____ |
| 10.      | 1,621        | L.F. | 7' x 5' Reinforced Concrete Box, C-1433 with required Bedding and Backfill, Complete in Place.<br>@ _____<br>Per Linear Foot            | \$ _____   | \$ _____ |
| 11.      | 30           | L.F. | 5' x 5' Reinforced Concrete Box, C-1433 with required Bedding and Backfill, Complete in Place.<br>@ _____<br>Per Linear Foot            | \$ _____   | \$ _____ |
| 12.      | 445          | L.F. | 30-Inch Reinforced Concrete Pipe, C-76, Class III, with required Bedding and Backfill. Complete in Place.<br>@ _____<br>Per Linear Foot | \$ _____   | \$ _____ |

| Item No. | Approx. Qty. | Unit | Description of Item with Unit Price Written in Words  | Unit Price | Amount   |
|----------|--------------|------|---|------------|----------|
| 13.      | 138          | L.F. | 24-Inch Reinforced Concrete Pipe, C-76, Class III, with required Bedding and Backfill. Complete in Place.<br>@ _____<br>Per Linear Foot | \$ _____   | \$ _____ |
| 14.      | 519          | L.F. | 18-Inch Reinforced Concrete Pipe, C-76, Class III, with required Bedding and Backfill. Complete in Place.<br>@ _____<br>Per Linear Foot | \$ _____   | \$ _____ |
| 15.      | 2            | EA.  | Type "C" Grate Inlet, Complete in Place.<br>@ _____<br>Per Each   | \$ _____   | \$ _____ |
| 16.      | 1            | EA.  | Saddle Inlet, Complete in Place.<br>@ _____<br>Per Each   | \$ _____   | \$ _____ |
| 17.      | 1            | EA.  | Reinforced Concrete Wingwall with Parallel Wings, Complete in Place.<br>@ _____<br>Per Each   | \$ _____   | \$ _____ |
| 18.      | 5            | EA.  | Reinforced Concrete Wingwall with 3:1 Flare Wings, Complete in Place.<br>@ _____<br>Per Each  | \$ _____   | \$ _____ |
| 19.      | 1,798        | S.Y. | Aggregate Base Course Driveway, Complete in Place.<br>@ _____<br>Per Square Yard  | \$ _____   | \$ _____ |
| 20.      | 7            | C.Y. | Reinforced Concrete Riprap, 4-Inch Thick, Complete in Place.<br>@ _____<br>Per Cubic Yard   | \$ _____   | \$ _____ |

| Item No. | Approx. Qty. | Unit | Description of Item with Unit Price Written in Words  | Unit Price | Amount   |
|----------|--------------|------|---|------------|----------|
| 21.      | 2,567        | L.F. | Six Foot (6') Chain Link Fence with Hot Dipped Galvanized 9 Gauge Wire Mesh, Three (3) Strands, 14 Gauge Barbed Wire, Reuse Existing Fabric, Complete in Place.<br>@ _____<br>Per Linear Foot | \$ _____   | \$ _____ |
| 22.      | 135          | L.F. | Remove and Dispose of 48-Inch Reinforced Concrete Pipe, Backfill to Existing Grades, Complete in Place.<br>@ _____<br>Per Linear Foot   | \$ _____   | \$ _____ |
| 23.      | 2,744        | L.F. | Remove and Dispose of 36-Inch Reinforced Concrete Pipe, Complete in Place.<br>@ _____<br>Per Linear Foot  | \$ _____   | \$ _____ |
| 24.      | 75           | L.F. | Remove and Dispose of 24-Inch Reinforced Concrete Pipe, Complete in Place.<br>@ _____<br>Per Linear Foot  | \$ _____   | \$ _____ |
| 25.      | 378          | L.F. | Remove and Dispose of 18-Inch Reinforced Concrete Pipe, Complete in Place.<br>@ _____<br>Per Linear Foot  | \$ _____   | \$ _____ |
| 26.      | 1            | EA.  | Remove and Dispose of existing Storm Sewer Inlet, Complete in Place.<br>@ _____<br>Per Each   | \$ _____   | \$ _____ |
| 27.      | 4,676        | L.F. | Remove and Dispose of Chain Link Fence, Complete in Place.<br>@ _____<br>Per Linear Foot  | \$ _____   | \$ _____ |

| Item No. | Approx. Qty. | Unit | Description of Item with Unit Price Written in Words                                       | Unit Price | Amount   |
|----------|--------------|------|--|------------|----------|
| 28.      | 38           | S.Y. | Remove and Replace Perimeter Access Road, Complete in Place.<br>@ _____<br>Per Square Yard | \$ _____   | \$ _____ |
| 29.      | 82           | AC.  | Permanent Broadcast Seeding, Complete in Place.<br>@ _____<br>Per Acre                     | \$ _____   | \$ _____ |
| 30.      | 82           | AC.  | Vegetative Watering, Complete in Place.<br>@ _____<br>Per Acre                             | \$ _____   | \$ _____ |
| 31.      | 82           | AC.  | Fertilizing, Complete in Place.<br>@ _____<br>Per Acre                                     | \$ _____   | \$ _____ |
| 35.      | 8            | EA.  | Type 1 Rock Filter Dam, Complete in Place.<br>@ _____<br>Per Each                          | \$ _____   | \$ _____ |

**TOTAL AMOUNT BID**      \$ \_\_\_\_\_

BIDDER acknowledges receipt of the following ADDENDUM:

\_\_\_\_\_

\_\_\_\_\_

\_\_\_\_\_

As provided in paragraph 11.03 of the General Conditions, estimated quantities are not guaranteed, and determinations of actual quantities and classifications are to be made by ENGINEER as provided in paragraph 9.08 of the General Conditions. Unit prices have been computed as provided in paragraph 11.03 of the General Conditions.



## **ARTICLE 6 - PAYMENT PROCEDURES**

### *6.01 Submittal and Processing of Payments*

A. CONTRACTOR shall submit Applications for Payment in accordance with Article 14 of the General Conditions. Applications for Payment will be processed by ENGINEER as provided in the General Conditions.

### *6.02 Progress Payments; Retainage*

A. OWNER shall make progress payments on account of the Contract Price on the basis of CONTRACTOR'S Applications for Payment on or about the 25<sup>th</sup> day of each month during performance of the Work as provided in paragraphs 6.02.A.1 and 6.02.A.2 below. All such payments will be measured by the schedule of values established in paragraph 2.07.A of the General Conditions (and in the case of Unit Price Work based on the number of units completed) or, in the event there is no schedule of values, as provided in the General Requirements:

1. Prior to Substantial Completion, progress payments will be made in an amount equal to the percentage indicated below but, in each case, less the aggregate of payments previously made and less such amounts as ENGINEER may determine or OWNER may withhold, in accordance with paragraph 14.02 of the General Conditions:

a. 95 % of Work completed (with the balance being retainage). If the Work has been 50% completed as determined by ENGINEER, and if the character and progress of the Work have been satisfactory to OWNER and ENGINEER, OWNER, on recommendation of ENGINEER, may determine that as long as the character and progress of the Work remain satisfactory to them, there will be no retainage on account of Work subsequently completed, in which case the remaining progress payments prior to Substantial Completion will be in an amount equal to 100% of the Work completed less the aggregate of payments previously made; and

b. 95 % of cost of materials and equipment not incorporated in the Work (with the balance being retainage).

2. Upon Substantial Completion, OWNER shall pay an amount sufficient to increase total payments to CONTRACTOR to 100 % of the Work completed, less such amounts as ENGINEER shall determine in accordance with paragraph 14.02.B.5 of the General Conditions and less 95 % of ENGINEER'S estimate of the value of Work to be completed or corrected as shown on the tentative list of items to be completed or corrected attached to the certificate of Substantial Completion.

### *6.03 Final Payment*

A. Upon final completion and acceptance of the Work in accordance with paragraph 14.07 of the General Conditions, OWNER shall pay the remainder of the Contract Price as recommended by ENGINEER as provided in said paragraph 14.07.

## **ARTICLE 7 - INTEREST**

7.01 All moneys not paid when due as provided in Article 14 of the General Conditions shall bear interest at the rate of 0 % per annum.

## **ARTICLE 8 - CONTRACTOR'S REPRESENTATIONS**

8.01 In order to induce OWNER to enter into this Agreement CONTRACTOR makes the following representations:

A. CONTRACTOR has examined and carefully studied the Contract Documents and the other related data identified in the Bidding Documents.

B. CONTRACTOR has visited the Site and become familiar with and is satisfied as to the general, local, and Site conditions that may affect cost, progress, and performance of the Work.

C. CONTRACTOR is familiar with and is satisfied as to all federal, state, and local Laws and Regulations that may affect cost, progress, and performance of the Work.

D. CONTRACTOR has obtained and carefully studied (or assumes responsibility for having done so) all, investigations, explorations, tests, studies, and data concerning conditions (surface, subsurface, and Underground Facilities) at or contiguous to the Site which may affect cost, progress, or performance of the Work or which relate to any aspect of the means, methods, techniques, sequences, and procedures of construction to be employed by CONTRACTOR, including applying the specific means, methods, techniques, sequences, and procedures of construction, if any, expressly required by the Contract Documents to be employed by CONTRACTOR, and safety precautions and programs incident thereto

E. CONTRACTOR does not consider that any further examinations, investigations, explorations, tests, studies, or data are necessary for the performance of the Work at the Contract Price, within the Contract Times, and in accordance with the other terms and conditions of the Contract Documents.

F. CONTRACTOR is aware of the general nature of work to be performed by OWNER and others at the Site that relates to the Work as indicated in the Contract Documents.

G. CONTRACTOR has correlated the information known to CONTRACTOR, information and observations obtained from visits to the Site, reports and drawings identified in the Contract Documents, and all additional examinations, investigations, explorations, tests, studies, and data with the Contract Documents.

H. CONTRACTOR has given ENGINEER written notice of all conflicts, errors, ambiguities, or discrepancies that CONTRACTOR has discovered in the Contract Documents, and the written resolution thereof by ENGINEER is acceptable to CONTRACTOR.

I. The Contract Documents are generally sufficient to indicate and convey understanding of all terms and conditions for performance and furnishing of the Work.

## **ARTICLE 9 - CONTRACT DOCUMENTS**

### *9.01 Contents*

A. The Contract Documents consist of the following:

1. This Agreement;
2. Performance Bond;
3. Payment Bond;
4. General Conditions;
5. Supplementary Conditions;
6. Specifications as listed in the table of contents of the Project Manual;
7. Drawings consisting of a cover sheet and sheets numbered 1 through 33 and 38 through 69, inclusive, with each sheet bearing the following general title: JACK BROOKS REGIONAL AIRPORT IMPROVEMENTS TO AIRPORT WEST DITCH;
9. Addenda;
10. The following which may be delivered or issued on or after the Effective Date of the Agreement and are not attached hereto:
  - a. Written Amendments;

- b. Work Change Directives;
  - c. Change Order(s).
- B. The documents listed in paragraph 9.01.A are attached to this Agreement (except as expressly noted otherwise above).
- C. There are no Contract Documents other than those listed above in this Article 9.
- D. The Contract Documents may only be amended, modified, or supplemented as provided in paragraph 3.05 of the General Conditions.

## **ARTICLE 10 - MISCELLANEOUS**

### 10.01 *Terms*

- A. Terms used in this Agreement will have the meanings indicated in the General Conditions.

### 10.02 *Assignment of Contract*

A. No assignment by a party hereto of any rights under or interests in the Contract will be binding on another party hereto without the written consent of the party sought to be bound; and, specifically but without limitation, moneys that may become due and moneys that are due may not be assigned without such consent (except to the extent that the effect of this restriction may be limited by law), and unless specifically stated to the contrary in any written consent to an assignment, no assignment will release or discharge the assignor from any duty or responsibility under the Contract Documents.

### 10.03 *Successors and Assigns*

A. OWNER and CONTRACTOR each binds itself, its partners, successors, assigns, and legal representatives to the other party hereto, its partners, successors, assigns, and legal representatives in respect to all covenants, agreements, and obligations contained in the Contract Documents.

### 10.04 *Severability*

A. Any provision or part of the Contract Documents held to be void or unenforceable under any Law or Regulation shall be deemed stricken, and all remaining provisions shall continue to be valid and binding upon OWNER and CONTRACTOR, who agree that the Contract Documents shall be reformed to replace such stricken provision or part thereof with a valid and enforceable provision that comes as close as possible to expressing the intention of the stricken provision.

### 10.05 *Other Provisions*

IN WITNESS WHEREOF, OWNER and CONTRACTOR have signed this Agreement in duplicate. One counterpart each has been delivered to OWNER and CONTRACTOR. All portions of the Contract Documents have been signed or identified by OWNER and CONTRACTOR or on their behalf.

This Agreement will be effective on \_\_\_\_\_, \_\_\_\_\_ (which is the Effective Date of the Agreement).

OWNER:

CONTRACTOR:

\_\_\_\_\_

\_\_\_\_\_

By: \_\_\_\_\_

By: \_\_\_\_\_

[CORPORATE SEAL]

[CORPORATE SEAL]

Attest \_\_\_\_\_

Attest \_\_\_\_\_

Address for giving notices:

Address for giving notices:

\_\_\_\_\_

\_\_\_\_\_

\_\_\_\_\_

\_\_\_\_\_

(If OWNER is a corporation, attach evidence of authority to sign. If OWNER is a public body, attach evidence of authority to sign and resolution or other documents authorizing execution of OWNER-CONTRACTOR Agreement.)

License No. \_\_\_\_\_  
(Where applicable)

Agent for service of process: \_\_\_\_\_

\_\_\_\_\_

(If CONTRACTOR is a corporation or a partnership, attach evidence of authority to sign.)

Designated Representative:

Designated Representative:

Name: \_\_\_\_\_

Name: \_\_\_\_\_

Title: \_\_\_\_\_

Title: \_\_\_\_\_

Address: \_\_\_\_\_

Address: \_\_\_\_\_

\_\_\_\_\_

\_\_\_\_\_

Phone: \_\_\_\_\_

Phone: \_\_\_\_\_

Facsimile: \_\_\_\_\_

Facsimile: \_\_\_\_\_

**SPECIAL PROVISION NO. 1  
TO  
ITEM NO. T-901**

**1. Replace Paragraph T-901-2.1 with the following:**

**901-2.1 SEED** *The species and application rates of grass, legume, and cover-crop seed furnished shall be those stipulated herein. Seed shall conform to the requirements of Fed. Spec. A-A-2671.*

*Seed shall be furnished separately or in mixtures in standard containers with the seed name, lot number, net weight, percentages of purity and of germination and hard seed, and percentage of maximum weed seed content clearly marked for each kind of seed. The Contractor shall furnish the Engineer duplicate signed copies of a statement by the vendor certifying that each lot of seed has been tested by a recognized laboratory for seed testing within 6 months of date of delivery. This statement shall include: name and address of laboratory, date of test, lot number for each kind of seed, and the results of tests as to name, percentages of purity and of germination, and percentage of weed content for each kind of seed furnished, and, in case of a mixture, the proportions of each kind of seed.*

*Seeds shall be applied as follows:*

***Bermuda grass at a rate of 2.7 lbs. PLS/ac.***

*Seeding shall be performed during the period between spring and fall inclusive, unless otherwise approved by the Engineer.*

**2. Replace Paragraph T-901-5.1 with the following:**

**901-5.1** *Payment shall be made at the contract unit price per **acre** or fraction thereof, which price and payment shall be full compensation for furnishing and placing all material and for all labor, equipment, tools, and incidentals necessary to complete the work prescribed in this item.*

*Payment will be made under:*

*Item 901-5.1                      Seeding, Fertilizer, and Watering per **acre***

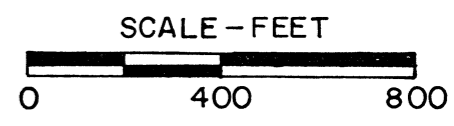
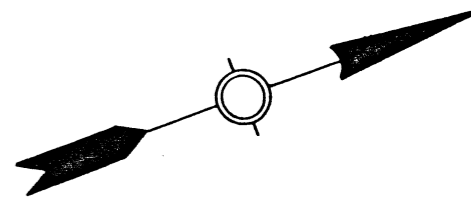
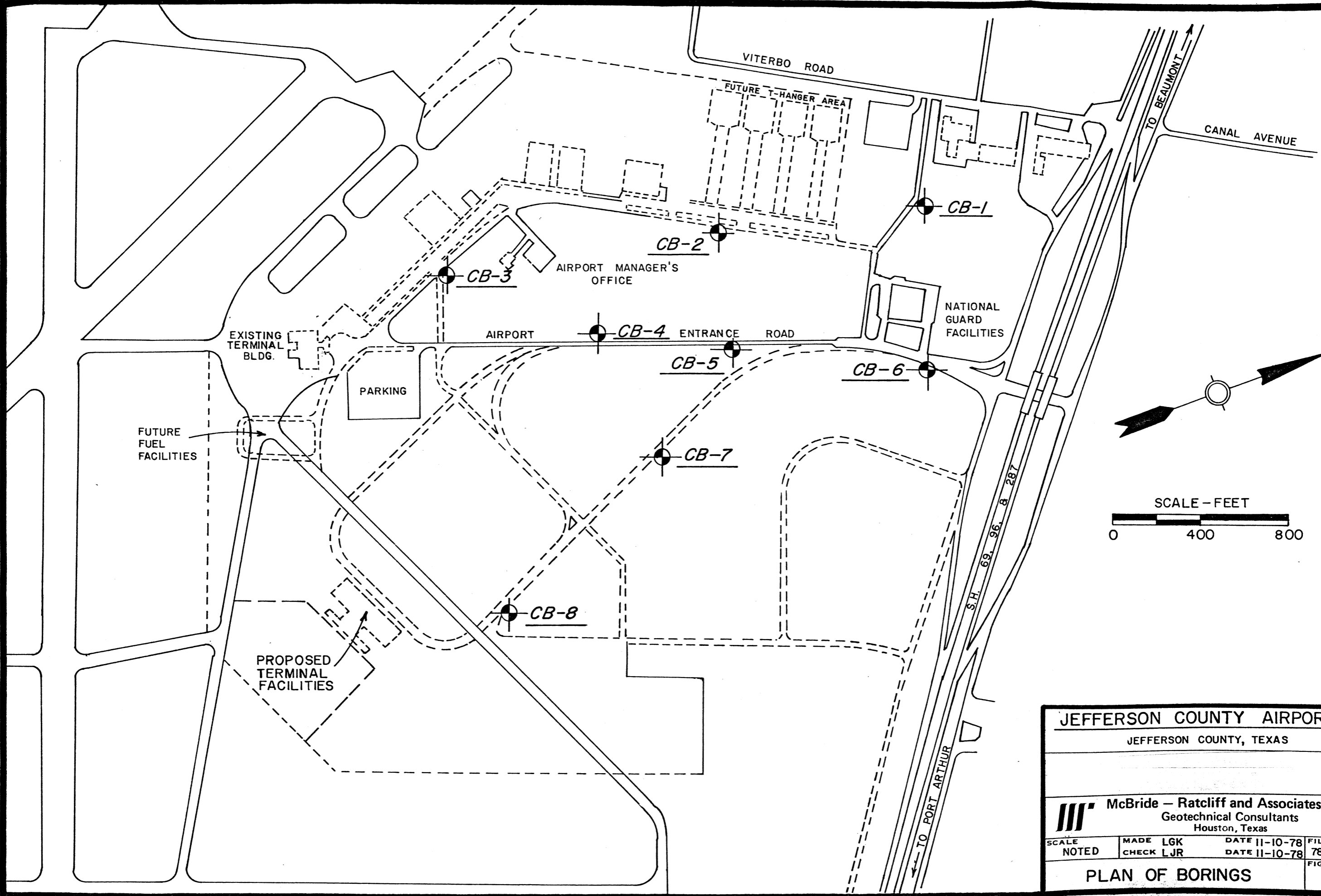

|  |                       |                                |                    |
|--|-----------------------|--------------------------------|--------------------|
| <b>JEFFERSON COUNTY AIRPORT</b>  |                       |                                |                    |
| JEFFERSON COUNTY, TEXAS  |                       |                                |                    |
|  <b>McBride - Ratcliff and Associates, Inc.</b><br>Geotechnical Consultants<br>Houston, Texas |                       |                                |                    |
| SCALE NOTED  | MADE LGK<br>CHECK LJR | DATE 11-10-78<br>DATE 11-10-78 | FILE NO.<br>78-216 |
| <b>PLAN OF BORINGS</b>   |                       |                                | FIGURE<br>1        |







# LOG OF BORING

PROJECT: Water and Wastewater Improvements  
Jefferson County Airport

BORING NO. CB-1  
FILE NO. 78-216  
DATE 11/8/78

CLIENT :

| SOIL SYMBOL | FIELD DATA   |         | LABORATORY DATA  |                                    |                      |                          | DRY AUGERED 0 to 12 ft.<br>WASH BORED<br><br>No free water encountered   |
|-------------|--------------|---------|--|------------------------------------|----------------------|--------------------------|--|
|             | DEPTH (feet) | SAMPLES | PENETRATION RESISTANCE (BLOWS/FOOT) OR POCKET PENETROMETER (TONS/SQ.FT.) | Compressive Strength (tons/sq.ft.) | Moisture Content (%) | Dry Density (lbs/cu.ft.) |  |
| 5           | 4.5+         |         |  |                                    |                      |                          | DESCRIPTION OF STRATUM<br><br>Very stiff gray, tan & red CLAY (CH) with roots<br>stiff tan and red @ 3 ft.<br><br>light gray, tan & red @ 5 ft.<br><br>with ferrous nodules @ 9 ft.<br><br>with calcareous nodules @ 11 ft.<br><br>Bottom @ 12 ft. |
|             | 3.5          |         |  |                                    |                      |                          |  |
|             | 2.0          | 0.71*   | 42   | 76                                 |                      |                          |  |
|             | 1.5          |         |  |                                    |                      |                          |  |
|             | 1.75         | 0.36*   | 34   | 87                                 |                      |                          |  |
|             | 1.75         |         |  |                                    |                      |                          |  |
| 10          | 2.25         | 0.48*   | 28   | 92                                 |                      |                          |  |
| 15          |              |         |  |                                    |                      |                          |  |

|   |   |  |   |   |   |   |
|---|---|--|---|---|---|---|
| <br>UNDISTURBED SAMPLE | <br>STANDARD PENETRATION | <br>NO RECOVERY | <br>SAND | <br>SILT | <br>CLAY | * slickensided failure<br>POCKET PENETROMETER - ESTIMATE OF UNCONFINED COMPRESSIVE STRENGTH |
|---|---|--|---|---|---|---|







# LOG OF BORING

**PROJECT:** Water and Wastewater Improvements  
 Jefferson County Airport

**CLIENT :**

**DATE:**

| SOIL SYMBOL | FIELD DATA   |  | LABORATORY DATA                    |                      |                          |                  | DRY AUGERED<br>WASH BORED                           | DESCRIPTION OF STRATUM |
|-------------|--------------|--|------------------------------------|----------------------|--------------------------|------------------|---|------------------------|
|             | DEPTH (feet) | PENETRATION RESISTANCE (BLOWS/FOOT) OR POCKET PENETROMETER (TONS/SQ.FT.) | Compressive Strength (tons/sq.ft.) | Moisture Content (%) | Dry Density (lbs/cu.ft.) | Liquid Limit (%) |   |                        |
| 0           |              |  |                                    |                      |                          |                  | 0 to 12 ft.   |                        |
| 5           | 4.5+         |  |                                    |                      |                          |                  | No free water encountered                           |                        |
| 5           | 3.0          | 2.48   | 22                                 | 103                  |                          |                  | Stiff gray and tan CLAY (CH) with silt seams        |                        |
| 7.5         | 1.5          |  |                                    |                      |                          |                  | with ferrous nodules @ 7 ft.                        |                        |
| 9           | 1.5          | 0.77   | 27                                 | 94                   |                          |                  |   |                        |
| 10          | 1.75         |  |                                    |                      |                          |                  | light gray, tan and red with silt seams and pockets |                        |
| 12          | 3.0          | 1.73   | 26                                 | 97                   |                          |                  | Bottom @ 12 ft.                                     |                        |
| 15          |              |  |                                    |                      |                          |                  |   |                        |

|   |   |  |   |   |   |   |
|---|---|--|---|---|---|---|
| <br>UNDISTURBED SAMPLE | <br>STANDARD PENETRATION | <br>NO RECOVERY | <br>SAND | <br>SILT | <br>CLAY | POCKET PENETROMETER - ESTIMATE OF UNCONFINED COMPRESSIVE STRENGTH |
|---|---|--|---|---|---|---|

McBRIDE - RATCLIFF & ASSOCIATES, INC.









# LOG OF BORING

PROJECT: Water and Wastewater Improvements  
Jefferson County Airport

BORING NO. CB-3  
FILE NO. 78-216  
DATE 11/8/78

CLIENT :

| SOIL SYMBOL | FIELD DATA      |         | LABORATORY DATA  |  |                         |                             | DRY AUGERED<br>WASH BORED |  |
|-------------|-----------------|---------|--|--|-------------------------|-----------------------------|---------------------------|--|
|             | DEPTH<br>(feet) | SAMPLES | PENETRATION RESISTANCE<br>(BLOWS/FOOT)<br>OR<br>POCKET PENETROMETER<br>(TONS/SQ.FT.) | Compressive<br>Strength<br>(tons/sq.ft.) | Moisture Content<br>(%) | Dry Density<br>(lbs/cu.ft.) |                           | Liquid Limit<br>(%)                            |
| 7           |                 |         | 2.25   |  |                         |                             |                           | DESCRIPTION OF STRATUM                         |
| 5           |                 |         | 2.0  | 1.20                                     | 27                      | 92                          |                           | Stiff dark gray SANDY CLAY (CL) "FILL"         |
| 5           |                 |         | 2.5  |  |                         |                             |                           | Stiff gray and tan CLAY (CH)                   |
| 10          |                 |         | 2.5  | 1.13*                                    | 25                      | 98                          |                           | with ferrous and calcareous nodules<br>@ 7 ft. |
|             |                 |         | 2.0  |  |                         |                             |                           |  |
|             |                 |         | 3.0  | 1.56                                     | 29                      | 96                          |                           | Bottom @ 12 ft.                                |

|  |  |   |   |   |   |  |
|--|--|---|---|---|---|--|
| <br>UNDISTURBED<br>SAMPLE | <br>STANDARD<br>PENETRATION | <br>NO<br>RECOVERY | <br>SAND | <br>SILT | <br>CLAY | * slickensided failure<br>POCKET PENETROMETER - ESTIMATE OF<br>UNCONFINED COMPRESSIVE STRENGTH |
|--|--|---|---|---|---|--|







# LOG OF BORING

PROJECT: Water and Wastewater Improvements  
Jefferson County Airport

BORING NO. CB-4  
FILE NO. 78-216  
DATE 11/8/78

CLIENT :

| SOIL SYMBOL | FIELD DATA   |         | LABORATORY DATA  |                                    |                      |                          | DRY AUGERED 0 to 12 ft.<br>WASH BORED<br><br>No free water encountered<br>Seepage into bottom of hole<br><br>DESCRIPTION OF STRATUM |  |
|-------------|--------------|---------|--|------------------------------------|----------------------|--------------------------|---|--|
|             | DEPTH (feet) | SAMPLES | PENETRATION RESISTANCE (BLOWS/FOOT) OR POCKET PENETROMETER (TONS/SQ.FT.) | Compressive Strength (tons/sq.ft.) | Moisture Content (%) | Dry Density (lbs/cu.ft.) |   | Liquid Limit (%)   |
| 5           | 4.5+         |         |  |                                    |                      |                          |   | Very stiff red and tan CLAY (CH) stiff @ 1 ft.<br><br>light gray and tan @ 3 ft.   |
|             | 2.5          |         |  |                                    |                      |                          |   |  |
| 10          | 1.5          | 1.07    | 25   | 100                                |                      |                          |   | Stiff light gray and tan SANDY CLAY (CL) with ferrous nodules<br><br>with silt seams and layers and calcareous nodules @ 7 ft. |
|             | 3.5          |         |  |                                    |                      |                          |   |  |
|             | 2.0          | 1.15    | 22   | 105                                |                      |                          |   |  |
| 15          | 2.0          |         |  |                                    |                      |                          |   | Bottom @ 12 ft.  |
|             | 3.0          | 1.34    | 26   | 98                                 |                      |                          |   |  |

|   |   |   |   |   |   |   |
|---|---|---|---|---|---|---|
|  |  |  |  |  |  | * slickensided failure<br>POCKET PENETROMETER - ESTIMATE OF UNCONFINED COMPRESSIVE STRENGTH |
| UNDISTURBED SAMPLE  | STANDARD PENETRATION  | NO RECOVERY   | SAND  | SILT  | CLAY  |   |

# LOG OF BORING

PROJECT: Water and Wastewater Improvements  
Jefferson County Airport

BORING NO. CB-5  
FILE NO. 78-216  
DATE 11/8/78

CLIENT :

| SOIL SYMBOL | FIELD DATA   |         | LABORATORY DATA  |                                    |                      |                          | DRY AUGERED 0 to 22 ft.<br>WASH BORED<br><br>Free water encountered @ 12 ft.   |                  |                      |     |             |     |   |     |    |     |    |
|-------------|--------------|---------|--|------------------------------------|----------------------|--------------------------|--|------------------|----------------------|-----|-------------|-----|---|-----|----|-----|----|
|             | DEPTH (feet) | SAMPLES | PENETRATION RESISTANCE (BLOWS/FOOT) OR POCKET PENETROMETER (TONS/SQ.FT.) | Compressive Strength (tons/sq.ft.) | Moisture Content (%) | Dry Density (lbs/cu.ft.) |  | Liquid Limit (%) | Plasticity Index (%) |     |             |     |   |     |    |     |    |
| 5           | 4.0          |         |  |                                    |                      |                          | Stiff dark gray and tan SANDY CLAY (CL) with roots   |                  |                      |     |             |     |   |     |    |     |    |
| 5           | 1.5          | 0.79    | 28   | 92                                 |                      |                          | Stiff light gray and tan CLAY (CH) with calcareous nodules @ 6 ft.   |                  |                      |     |             |     |   |     |    |     |    |
|             | 1.75         |         |  |                                    |                      |                          |  |                  |                      |     |             |     |   |     |    |     |    |
|             | 1.75         | 1.28    | 26   | 100                                |                      |                          |  |                  |                      |     |             |     |   |     |    |     |    |
| 10          | 2.0          |         |  |                                    |                      |                          |  |                  |                      |     |             |     |   |     |    |     |    |
|             | 2.5          | 1.47    | 25   | 99                                 |                      |                          | with ferrous nodules and sand pockets @ 11 ft.   |                  |                      |     |             |     |   |     |    |     |    |
| 15          | 3.0          | 0.98    | 23   | 105                                |                      |                          | Stiff light gray and tan SANDY CLAY (CL) (wet)   |                  |                      |     |             |     |   |     |    |     |    |
| 20          | 3.5          | 1.52    | 22   | 104                                |                      |                          | with ferrous nodules @ 21 ft.  |                  |                      |     |             |     |   |     |    |     |    |
|             |              |         |  |                                    |                      |                          | Bottom @ 22 ft.  |                  |                      |     |             |     |   |     |    |     |    |
|             |              |         |  |                                    |                      |                          | <u>WATERTABLE OBSERVATIONS</u><br><table style="margin-left: auto; margin-right: auto;"> <thead> <tr> <th style="text-align: left;">Depth (ft)</th> <th style="text-align: left;">Time (min)</th> </tr> </thead> <tbody> <tr> <td>7.5</td> <td>1st reading</td> </tr> <tr> <td>6.7</td> <td>5</td> </tr> <tr> <td>6.6</td> <td>10</td> </tr> <tr> <td>6.6</td> <td>35</td> </tr> </tbody> </table> | Depth (ft)       | Time (min)           | 7.5 | 1st reading | 6.7 | 5 | 6.6 | 10 | 6.6 | 35 |
| Depth (ft)  | Time (min)   |         |  |                                    |                      |                          |  |                  |                      |     |             |     |   |     |    |     |    |
| 7.5         | 1st reading  |         |  |                                    |                      |                          |  |                  |                      |     |             |     |   |     |    |     |    |
| 6.7         | 5            |         |  |                                    |                      |                          |  |                  |                      |     |             |     |   |     |    |     |    |
| 6.6         | 10           |         |  |                                    |                      |                          |  |                  |                      |     |             |     |   |     |    |     |    |
| 6.6         | 35           |         |  |                                    |                      |                          |  |                  |                      |     |             |     |   |     |    |     |    |

|                    |                      |             |      |      |      |   |
|--------------------|----------------------|-------------|------|------|------|---|
| UNDISTURBED SAMPLE | STANDARD PENETRATION | NO RECOVERY | SAND | SILT | CLAY | POCKET PENETROMETER - ESTIMATE OF UNCONFINED COMPRESSIVE STRENGTH |
|--------------------|----------------------|-------------|------|------|------|---|

# LOG OF BORING

PROJECT: Water and Wastewater Improvements  
Jefferson County Airport







BORING NO. CB-6

FILE NO. 78-216

DATE 11/8/78

CLIENT :

| SOIL SYMBOL | FIELD DATA   |         | LABORATORY DATA  |                                    |                      |                          | DESCRIPTION OF STRATUM   |  |
|-------------|--------------|---------|--|------------------------------------|----------------------|--------------------------|--|--|
|             | DEPTH (feet) | SAMPLES | PENETRATION RESISTANCE (BLOWS/FOOT) OR POCKET PENETROMETER (TONS/SQ.FT.) | Compressive Strength (tons/sq.ft.) | Moisture Content (%) | Dry Density (lbs/cu.ft.) |  | Liquid Limit (%)   |
|             |              |         |  |                                    |                      |                          | DRY AUGERED 0 to 12 ft.<br>WASH BORED<br><br>No free water encountered |  |
| 5           |              |         | 2.0  |                                    |                      |                          |  | Stiff tan and gray CLAY (CH) with ferrous and calcareous nodules<br><br>light gray and tan @ 5 ft.<br><br>slickensided @ 7 ft. |
|             |              |         | 2.0  | 0.96                               | 27                   | 94                       |  |  |
|             |              |         | 2.0  | 0.68*                              | 23                   | 100                      |  |  |
| 10          |              |         | 2.5  |                                    |                      |                          |  |  |
|             |              |         | 2.5  | 0.92*                              | 35                   | 88                       |  |  |
| 15          |              |         |  |                                    |                      |                          |  |  |

|   |   |  |   |   |   |   |
|---|---|--|---|---|---|---|
| <br>UNDISTURBED SAMPLE | <br>STANDARD PENETRATION | <br>NO RECOVERY | <br>SAND | <br>SILT | <br>CLAY | * slickensided failure<br>POCKET PENETROMETER - ESTIMATE OF UNCONFINED COMPRESSIVE STRENGTH |
|---|---|--|---|---|---|---|







# LOG OF BORING

PROJECT: Water and Wastewater Improvements  
Jefferson County Airport

BORING NO. CB-7  
FILE NO. 78-216  
DATE 11/8/78

CLIENT :

| SOIL SYMBOL | FIELD DATA   |         | LABORATORY DATA                    |                      |                          |                  | DESCRIPTION OF STRATUM   |
|-------------|--------------|---------|------------------------------------|----------------------|--------------------------|------------------|--|
|             | DEPTH (feet) | SAMPLES | Compressive Strength (tons/sq.ft.) | Moisture Content (%) | Dry Density (lbs/cu.ft.) | Liquid Limit (%) |  |
|             |              |         |                                    |                      |                          |                  | DRY AUGERED 0 to 12 ft.<br>WASH BORED<br><br>No free water encountered |
| 5           | 4.5+         |         |                                    |                      |                          |                  | Very stiff dark gray SANDY CLAY (CL) with roots                        |
| 5           | 2.0          |         | 1.06                               | 29                   | 91                       |                  | Stiff tan and red CLAY (CH)<br>light gray and gray                     |
| 5           | 2.0          |         |                                    |                      |                          |                  |  |
| 5           | 2.75         |         | 1.42                               | 25                   | 101                      |                  |  |
| 10          | 2.75         |         |                                    |                      |                          |                  | Stiff light gray and tan SILTY CLAY (CL)                               |
| 10          | 3.0          |         | 1.31                               | 25                   | 97                       |                  | w/clay pockets and silt seams @ 12 ft.                                 |
| 15          |              |         |                                    |                      |                          |                  | Bottom @ 12 ft.  |

|   |   |  |   |   |   |   |
|---|---|--|---|---|---|---|
| <br>UNDISTURBED SAMPLE | <br>STANDARD PENETRATION | <br>NO RECOVERY | <br>SAND | <br>SILT | <br>CLAY | POCKET PENETROMETER - ESTIMATE OF UNCONFINED COMPRESSIVE STRENGTH |
|---|---|--|---|---|---|---|







# LOG OF BORING

PROJECT: Water and Wastewater Improvements  
 Jefferson County Airport

BORING NO. CB-8  
 FILE NO. 78-216  
 DATE 11/8/78

CLIENT :

| SOIL SYMBOL | FIELD DATA   |         | LABORATORY DATA   |                                    |                      |                          | DRY AUGERED 0 to 12 ft.<br>WASH BORED<br><br>No free water encountered<br><br>DESCRIPTION OF STRATUM |   |
|-------------|--------------|---------|---|------------------------------------|----------------------|--------------------------|--|---|
|             | DEPTH (feet) | SAMPLES | PENETRATION RESISTANCE (BLOWS/FOOT) OR POKET PENETROMETER (TONS/SQ.FT.) | Compressive Strength (tons/sq.ft.) | Moisture Content (%) | Dry Density (lbs/cu.ft.) |  | Liquid Limit (%)  |
| 5           |              | 2.5     |   |                                    |                      |                          |  | Stiff tan and red CLAY (CH) with roots<br><br>light gray and tan @ 5 ft.<br><br>with ferrous and calcareous nodules @ 10 ft.<br><br>Bottom @ 12 ft. |
|             |              | 2.5     | 1.04  | 28                                 | 95                   |                          |  |   |
|             |              | 2.0     |   |                                    |                      |                          |  |   |
|             |              | 2.0     | 1.15  | 24                                 | 97                   |                          |  |   |
| 10          |              | 2.5     |   |                                    |                      |                          |  |   |
|             |              | 2.75    | 1.30  | 27                                 | 95                   |                          |  |   |
| 15          |              |         |   |                                    |                      |                          |  |   |

|   |   |  |   |   |   |   |
|---|---|--|---|---|---|---|
| <br>UNDISTURBED SAMPLE | <br>STANDARD PENETRATION | <br>NO RECOVERY | <br>SAND | <br>SILT | <br>CLAY | POCKET PENETROMETER - ESTIMATE OF UNCONFINED COMPRESSIVE STRENGTH |
|---|---|--|---|---|---|---|

# PLAN LEGEND

## PLAN

### EXISTING

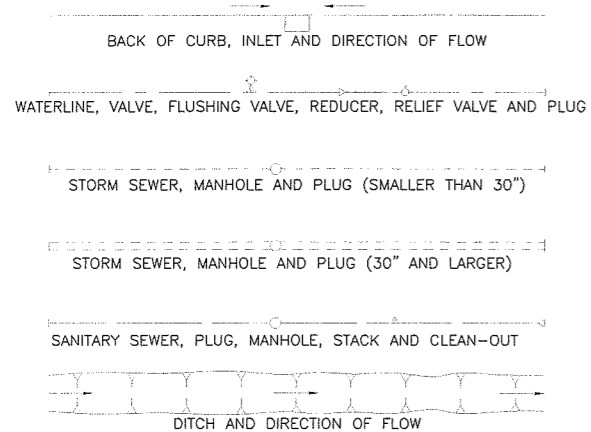

### PROPOSED

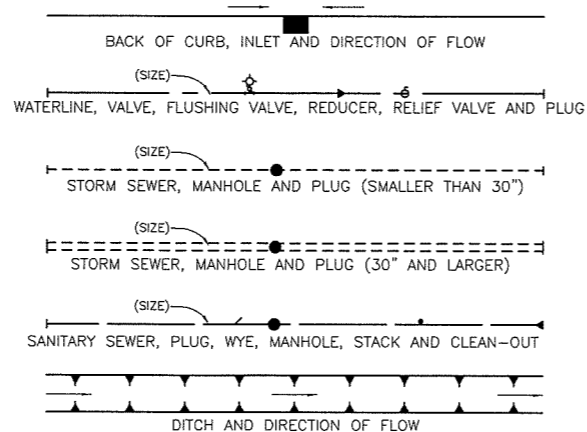

## MISCELLANEOUS PLAN

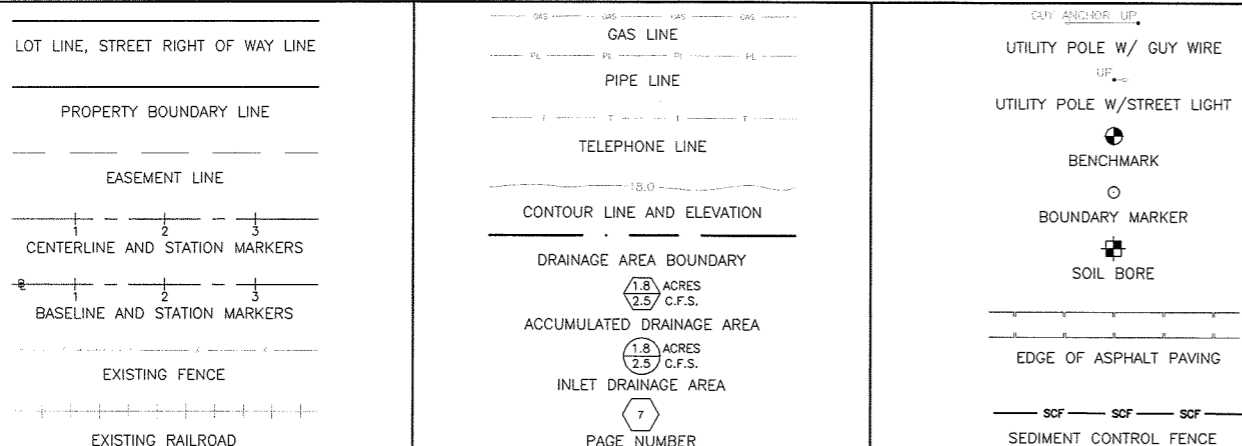

## LIST OF ABBREVIATIONS

|          |                         |            |                    |            |                         |        |                              |
|----------|-------------------------|------------|--------------------|------------|-------------------------|--------|------------------------------|
| AC       | ACRE                    | DIA        | DIAMETER           | GALV       | GALVANIZED              | RCP    | REINFORCED CONCRETE PIPE     |
| B/B      | BACK TO BACK            | DR.        | DRIVE              | HWY        | HIGHWAY                 | REQ'D  | REQUIRED                     |
| BL       | BASE LINE               | D.I.P.     | DUCTILE IRON PIPE  | I.P., I.R. | IRON PIPE, IRON ROD     | RT     | RIGHT (X-SECTION NOTES)      |
| BM       | BENCH MARK              | ESMT       | EASEMENT           | LT         | LEFT (X-SECTION NOTES)  | ROW    | RIGHT-OF-WAY                 |
| B.L.     | BUILDING LINE           | EB         | ELECTRICAL BOX     | MH         | MANHOLE                 | SPEC'D | SPECIFIED                    |
| B.V.     | BUTTERFLY VALVE         | EL ELEV    | ELEVATION          | MAX        | MAXIMUM                 | SF     | SQUARE FEET, FOOT            |
| C.I.     | CAST IRON               | ER         | END RETURN         | M.S.L.     | MEAN SEA LEVEL          | SS     | STAINLESS STEEL              |
| C/C      | CENTER TO CENTER        | EQ SPA, ES | EQUALLY SPACED     | MIN        | MINIMUM                 | STA    | STATION                      |
| C        | CENTERLINE              | EXIST      | EXISTING           | MON.       | MONUMENT                | STL    | STEEL                        |
| CONC     | CONCRETE                | F.B.       | FIELDBOOK          | NTS        | NOT TO SCALE            | ST.    | STREET                       |
| CONC MON | CONCRETE MONUMENT       | F.G.       | FINISHED GRADE     | NO.        | NUMBER                  | TBM    | TEMPORARY BENCH MARK         |
| C.J.     | CONSTRUCTION JOINT      | F.H.       | FIRE HYDRANT       | O.C.E.W.   | ON CENTER EACH WAY      | TC     | TOP OF CURB                  |
| C.P.P.   | CORRUGATED PLASTIC PIPE | F.S.       | FIRE SPRINKLER     | PVMT       | PAVEMENT                | TP     | TOP OF PAVEMENT              |
| X-SECT   | CROSS-SECTION           | FL         | FLOW LINE (INVERT) | P.V.C.     | POLYVINYL CHLORIDE      | TYP    | TYPICAL                      |
| C.Y.     | CUBIC YARD              | FT         | FOOT, FEET         | PROP       | PROPOSED                | UP     | UTILITY POLE                 |
|          |                         | FND        | FOUND              | RCB        | REINFORCED CONCRETE BOX | VPI    | VERTICAL POINT OF INFLECTION |

## GENERAL CONSTRUCTION NOTES

- ALL ELEVATIONS SHOWN ARE M.S.L. DATUM PLUS 100 FEET.
- CONTRACTOR TO VERIFY LOCATION AND ELEVATION OF EXISTING FACILITIES PRIOR TO CONSTRUCTION OF PROPOSED FACILITIES.
- SPOIL FROM CONSTRUCTION SHALL BE SPREAD WITHIN PROPERTY LIMITS OR AS DESIGNATED BY THE OWNER IN A MANNER TO PREVENT BONDING FROM RAINFALL AND IN CONFORMANCE WITH THE SITE GRADING PLAN APPROVED BY THE SOUTHEAST TEXAS REGIONAL AIRPORT.
- CONTOURS SHOWN INDICATE EXISTING NATURAL GROUND PRIOR TO CLEARING AND GRUBBING.
- CONTRACTOR WILL BE RESPONSIBLE FOR CONTACTING ALL UTILITY COMPANIES PRIOR TO CONSTRUCTION IN AREA OF POSSIBLE UNDERGROUND UTILITIES WHICH MAY NOT BE SHOWN ON DRAWING.
- CONTRACTOR SHALL NOTIFY ALL UTILITY COMPANIES WITH EXISTING FACILITIES IN AREA OF CONSTRUCTION AT LEAST 48 HOURS BEFORE BEGINNING CONSTRUCTION IN THAT AREA. THE FOLLOWING IS A PARTIAL LIST OF CONTACTS:

|   |  |
|---|--|
| TEXAS GAS SERVICE                             | MR. KEITH HARPER<br>409-963-7110       |
| ENERGY  | MR. PHILLIP SCOTT<br>409-982-5830      |
| SOUTHWESTERN BELL<br>(PORT ARTHUR, GROVES)    | MR. HAYWARD GREEN<br>409-839-7887      |
| TIME WARNER COMMUNICATIONS                    | MR. HERCEL STRACENER<br>409-720-5501   |
| JEFFERSON COUNTY<br>ENGINEERING DEPARTMENT    | MR. DON RAO<br>409-835-8584            |
| TEXAS DEPARTMENT<br>OF TRANSPORTATION         | MR. DUANE BROWNING, PE<br>409-722-8377 |
| JEFFERSON COUNTY D.D. #7                      | MR. RALPH MITCHELL<br>409-985-4369     |
| KINDER MORGAN PIPELINE CO.<br>SYSTEM OPERATOR | MR. BEN FERGUSON<br>409-842-4223       |
| JACK BROOKS REGIONAL AIRPORT                  | MR. DUKE YOUMANS<br>409-284-1241       |
| TEXAS ONE CALL SYSTEM                         | 1-800-245-4545                         |
| DIG-TESS                                      | 1-800-344-8377                         |

## STORM SEWER CONSTRUCTION NOTES

- ALL RCP STORM SEWER AND LEADS TO BE A.S.T.M., C-76, CLASS III, REINFORCED CONCRETE PIPE, INSTALLED WITH CLASS "A" BEDDING AS SHOWN ON PLANS.
- CONCRETE BOX CULVERT SHALL CONFORM TO ASTM C1433 AND MEET THE REQUIREMENTS SET IN ITEM 462 OF THE 2004 TEXAS DEPARTMENT OF TRANSPORTATION, STANDARD SPECIFICATIONS FOR CONSTRUCTION OF HIGHWAYS, STREETS, AND BRIDGES. INSTALL WITH CLASS "A" BEDDING.
- SPOIL FROM CHANNEL EXCAVATION TO BE HAULED AND SPREAD AT DESIGNATED SPOIL AREA AS SHOWN ON PROJECT LOCATION MAP. ROUGH GRADE SPOIL SO THAT NO WATER WILL POND. NO SEPARATE PAY FOR HAULING AND SPREADING.
- CONTRACTOR SHALL USE JEFFERSON COUNTY DRAINAGE DISTRICT NO. 7'S PIPE ENTRANCE DRAWING NO. 2007SD-01-501.8 FOR ALL PIPE ENTRANCES ON ALIGNMENT "A" FROM STATION 0+00 TO STATION 55+50.
- CONTRACTOR SHALL USE JEFFERSON COUNTY DRAINAGE DISTRICT NO. 7'S PIPE ENTRANCE DRAWING NO. 2005SD-08-501.6 FOR ALL PIPE ENTRANCES ON ALIGNMENT "A" FROM STATION 55+50 TO STATION 96+00.
- CONTRACTOR SHALL UTILIZE DRIVEWAY PAVING SECTION SHOWN ON SHEET 24 FOR ALL DRIVEWAY CROSSING LOCATED ON ALIGNMENT "A".
- ALL CONCRETE WINGWALLS SHALL BE CONSTRUCTED WITH CONCRETE FOOTING AS SHOWN ON SHEET 24.

## AIRPORT FENCE CONSTRUCTION NOTES

- POSTS, RAILS, AND BRACES SHALL BE HOT-DIPPED GALVANIZED AND CONFORM TO REQUIREMENTS OF GROUP 1A (SCHEDULE 40) COATINGS CONFORMING TO TYPE A OR GROUP 1C, EXTERNAL COATING TYPE B AND INTERNAL COATING TYPE B OR D.
- LATCH FORKED TYPE 10 PERMIT OPERATION FROM EITHER SIDE, PROVIDING PADLOCK EYE.
- BARBED WIRE: 3-2 STRAND 12 1/2 GA. 4P POINT BARBS SPACED 5" O.C. GALV.
- STRETCHER BAR: CROSS SECTION 3/16 x 3/4 ONE PIECE LENGTHS TO FILL HEIGHT OF FABRIC. PROVIDE ONE BAR FOR EACH GATE AND END POST, 2 FOR CORNERS.
- ALL CONCRETE IS TO BE CLASS "A" 3000 PSI CONCRETE.
- "L" BAR NO. 5 SMOOTH BAR TO BE PLACED AS LOCKING PIECE TO KEEP GATE FROM SWINGING WHEN LOCKED.
- TENSION WIRE TO BE 7GA. MARCELLED GALVANIZED STEEL WIRE.
- CLEARANCE FROM GATES TO FINISHED GRADE TO BE 4".
- CONTRACTOR TO PROVIDE NO. 2 MASTER LOCK, OR EQUAL FOR EACH GATE. ALL LOCKS TO BE KEYPED TO A MASTER KEY.
- WHERE FENCE POSTS ARE TO BE INSTALLED IN PAVED AREAS, CONTRACTOR SHALL MAKE NEAT CYLINDRICAL CUTS IN CONCRETE FOR INSTALLING POST ANCHOR FOOTINGS.
- FENCING INDICATED FOR DEMOLITION SHALL BECOME THE PROPERTY OF THE CONTRACTOR AND BE DISPOSED OFFSITE. DEMOLITION SHALL INCLUDE REMOVAL OF POSTS, FABRIC RAILS, AND FOOTINGS.

## INDEX TO SHEETS

|       |   |
|-------|---|
| 1     | COVERSHEET  |
| 2     | LEGEND AND CONSTRUCTION NOTES   |
| 3     | PERIMETER SECURITY FENCE GENERAL NOTES  |
| 4     | SUMMARY OF STORM SEWER QUANTITIES   |
| 5     | SUMMARY OF REMOVAL  |
| 6     | PROJECT LOCATION MAP  |
| 7     | FILL AREA LAYOUT  |
| 7A    | CLEARING AND GRUBBING LAYOUT  |
| 7B    | EXISTING DITCH FILL LOCATION  |
| 8-9   | PROPOSED DD7 DRAINAGE EASEMENTS   |
| 10    | PERIMETER SECURITY FENCE AIRPORT SAFETY PLAN                                  |
| 11    | PROPOSED DITCH ALIGNMENTS   |
| 12    | ALIGNMENT "A" PLAN AND PROFILE STA. 0+00 TO 7+50                              |
| 13    | ALIGNMENT "A" PLAN AND PROFILE STA. 7+50 TO 15+50                             |
| 14    | ALIGNMENT "A" PLAN AND PROFILE STA. 15+50 TO 23+50                            |
| 15    | ALIGNMENT "A" PLAN AND PROFILE STA. 23+50 TO 31+50                            |
| 16    | ALIGNMENT "A" PLAN AND PROFILE STA. 31+50 TO 39+50                            |
| 17    | ALIGNMENT "A" PLAN AND PROFILE STA. 39+50 TO 47+50                            |
| 18    | ALIGNMENT "A" PLAN AND PROFILE STA. 47+50 TO 55+50                            |
| 19    | ALIGNMENT "A" PLAN AND PROFILE STA. 55+50 TO 63+50                            |
| 20    | ALIGNMENT "A" PLAN AND PROFILE STA. 63+50 TO 71+50                            |
| 21    | ALIGNMENT "A" PLAN AND PROFILE STA. 71+50 TO 79+50                            |
| 22    | ALIGNMENT "A" PLAN AND PROFILE STA. 79+50 TO 87+50                            |
| 23    | ALIGNMENT "A" PLAN AND PROFILE STA. 87+50 TO 95+50                            |
| 24    | ALIGNMENT "A" PLAN AND PROFILE STA. 95+50 TO END                              |
| 25    | ALIGNMENT "B" PLAN AND PROFILE STA. 0+00 TO 7+50                              |
| 26    | ALIGNMENT "B" PLAN AND PROFILE STA. 7+50 TO 14+50                             |
| 27    | ALIGNMENT "B" PLAN AND PROFILE STA. 14+50 TO END                              |
| 28    | ALIGNMENT "C" PLAN AND PROFILE STA. 0+00 TO 7+50                              |
| 29    | ALIGNMENT "C" PLAN AND PROFILE STA. 7+50 TO 15+50                             |
| 30    | ALIGNMENT "C" PLAN AND PROFILE STA. 15+50 TO 23+50                            |
| 31    | ALIGNMENT "C" PLAN AND PROFILE STA. 23+50 TO END                              |
| 32    | ALIGNMENT "D" PLAN AND PROFILE STA. 0+00 TO END                               |
| 33    | ALIGNMENT "E" PLAN AND PROFILE STA. 0+00 TO END                               |
| 34    | ALIGNMENT 16/34 NORTH PLAN AND PROFILE  |
| 35    | ALIGNMENT 16/34 SOUTH PLAN AND PROFILE  |
| 36    | ALIGNMENT 12/30 NORTH PLAN AND PROFILE  |
| 37    | ALIGNMENT 12/30 SOUTH PLAN AND PROFILE  |
| 38    | STORM WATER POLLUTION PREVENTION PLAN   |
| 39    | CONSTRUCTION DETAILS  |
| 40    | DRAINAGE DISTRICT NO. 7 DETAILS   |
| 41-66 | DITCH CROSS SECTIONS  |
| 67    | TEMPORARY EROSION SEDIMENT AND WATER POLLUTION CONTROL MEASUREMENTS           |
| 68    | CONCRETE WINGWALLS WITH FLARED WINGS FOR 0° SKEW BOX CULVERTS                 |
| 69    | CONCRETE WINGWALLS WITH PARALLEL WINGS FOR SKEWED AND NON-SKEWED BOX CULVERTS |

## MISCELLANEOUS CONSTRUCTION NOTES

- THE GRUBBING OF ALL STUMPS WITHIN PROPOSED EASEMENT SHALL BE REQUIRED.
- CONTRACTOR SHALL CLEAR ALL VEGETATION WITHIN AREAS OF EMBANKMENT AND OUTSIDE OF THE PROPOSED EASEMENT TO A MINIMUM OF TWO FEET BELOW FINAL GRADE.
- CONTRACTOR SHALL SPREAD ALL CUT UP MATERIALS WITHIN THE AIRPORT PROPERTY AND OUTSIDE OF THE PROPOSED EASEMENT AS DIRECTED BY THE AIRPORT REPRESENTATIVES.
- CONTRACTOR SHALL BE ALLOWED UP TO FIVE TEMPORARY GATES AT NO ADDITIONAL COST TO THE AIRPORT. THE GATES CAN BE UP TO TWENTY FEET IN WIDTH AND MATCH THE SPECIFICATIONS OF THE EXISTING GATES. THESE GATES MUST BE CHAINED AND LOCKED AT THE END OF EACH DAY. THE LOCATION OF THE TEMPORARY GATES SHALL BE DETERMINED BY THE CONTRACTOR AND APPROVED BY THE AIRPORT REPRESENTATIVE.
- CONTRACTOR SHALL REMOVE ALL TEMPORARY GATES AND REPAIR THE CHAINLINK FENCE TO ORIGINAL OR BETTER CONDITION AT THE CONCLUSION OF THE PROJECT. THIS INCLUDES REPAIRING DAMAGE TO EXISTING FENCE AND DRAINAGE SWALES DURING CONSTRUCTION.

SHEET  
**2**

AIRPORT WEST DITCH IMPROVEMENTS  
 JACK BROOKS REGIONAL AIRPORT  
 LEGEND AND CONSTRUCTION NOTES  
 JEFFERSON COUNTY, TEXAS

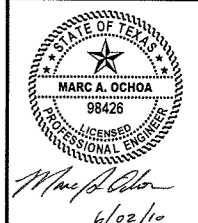

TEXAS REGISTERED  
ENGINEERING FIRM  
F-30

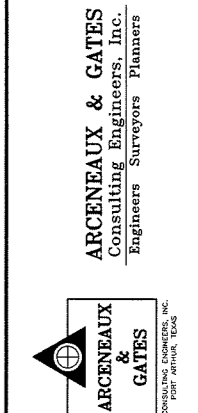

**SUMMARY OF STORM SEWER QUANTITIES**

| ALIGNMENT           | SHEET NUMBER                  | STATION TO STATION  | EXCAV  | EMBAN K | REPL PRMTR RD | CL FEN W/ BW | DRVWAYS | CONC W-WALL W/ PW | CONC W-WALL W/ FW | 4" CONC RIPRAP | REINF CONC BOX (12'x6') | REINF CONC BOX (12'x5') | REINF CONC BOX (8'x5') | REINF CONC BOX (7'x5') | REINF CONC BOX (5'x5') | RC PIPE (CL III) (30') | RC PIPE (CL III) (24') | RC PIPE (CL III) (18') | SADDLE INLET | GRATE INLET |        |
|---------------------|-------------------------------|---------------------|--------|---------|---------------|--------------|---------|-------------------|-------------------|----------------|-------------------------|-------------------------|------------------------|------------------------|------------------------|------------------------|------------------------|------------------------|--------------|-------------|--------|
|                     |                               |                     | (C.Y.) | (C.Y.)  | (S.Y.)        | (L.F.)       | (S.Y.)  | (EACH)            | (EACH)            | (C.Y.)         | (L.F.)                  | (L.F.)                  | (L.F.)                 | (L.F.)                 | (L.F.)                 | (L.F.)                 | (L.F.)                 | (L.F.)                 | (L.F.)       | (EACH)      | (EACH) |
| "A"                 | 12                            | Sta. 0+00 to 7+50   | 2,047  | 1,381   |               |              | 578     | 1                 | 1                 |                | 60                      |                         |                        |                        |                        |                        |                        | 74                     |              |             |        |
|                     | 13                            | Sta. 7+50 to 15+50  | 3,143  | 1,870   |               |              |         |                   |                   |                |                         |                         |                        |                        |                        |                        |                        |                        |              |             |        |
|                     | 14                            | Sta. 15+50 to 23+50 | 3,079  | 2,229   | 38            |              |         |                   |                   |                |                         |                         |                        |                        |                        |                        |                        |                        |              |             |        |
|                     | 15                            | Sta. 23+50 to 31+50 | 2,286  | 2,820   |               |              | 509     |                   |                   |                |                         | 30                      |                        |                        |                        |                        |                        |                        | 166          |             |        |
|                     | 16                            | Sta. 31+50 to 39+50 | 1,872  | 3,675   |               |              |         |                   |                   |                |                         |                         |                        |                        |                        |                        |                        |                        | 79           |             |        |
|                     | 17                            | Sta. 39+50 to 47+50 | 5,993  | 966     |               |              |         |                   |                   |                |                         |                         |                        |                        |                        |                        |                        | 74                     |              |             |        |
|                     | 18                            | Sta. 47+50 to 55+50 | 10,613 | 0       |               |              | 390     |                   |                   |                |                         |                         |                        | 40                     |                        |                        |                        |                        |              |             |        |
|                     | 19                            | Sta. 55+50 to 63+50 | 9,729  | 0       |               |              |         |                   |                   |                |                         |                         |                        |                        |                        |                        |                        |                        |              |             |        |
|                     | 20                            | Sta. 63+50 to 71+50 | 7,404  | 733     |               |              |         |                   |                   |                |                         |                         |                        |                        |                        |                        |                        |                        |              |             |        |
|                     | 21                            | Sta. 71+50 to 79+50 | 2,875  | 1,137   |               | 680          | 321     |                   |                   |                |                         |                         |                        | 30                     |                        |                        |                        |                        | 64           |             |        |
|                     | 22                            | Sta. 79+50 to 87+50 | 2,893  | 1,134   |               |              | 800     |                   |                   |                |                         |                         |                        |                        |                        |                        |                        |                        |              | 141         |        |
|                     | 23                            | Sta. 87+50 to 95+50 | 2,548  | 619     |               |              | 810     |                   |                   |                |                         |                         |                        |                        |                        |                        |                        |                        |              | 59          |        |
|                     | 24                            | Sta. 95+50 to 97+01 | 499    | 131     |               |              | 277     |                   |                   | 4              |                         |                         |                        |                        |                        | 30                     |                        |                        |              |             | 1      |
|                     | Alignment "A" Total           |                     |        | 54,981  | 16,695        | 38           | 2,567   | 1,798             | 1                 | 5              | 0                       | 60                      | 30                     | 30                     | 40                     | 30                     | 0                      | 138                    | 519          | 0           | 1      |
| "B"                 | 25                            | Sta. 0+00 to 7+50   |        |         |               |              |         |                   |                   |                |                         |                         |                        |                        | 1,581                  |                        |                        |                        |              | 1           |        |
|                     | 26                            | Sta. 7+50 to 14+50  |        |         |               |              |         |                   |                   |                |                         |                         |                        |                        |                        |                        |                        |                        |              | 1           |        |
|                     | 27                            | Sta. 14+50 to 15+93 |        |         |               |              |         |                   |                   |                |                         |                         |                        |                        |                        |                        |                        |                        |              |             |        |
| Alignment "B" Total |                               |                     | 0      | 0       |               | 0            | 0       | 0                 | 0                 | 0              | 0                       | 0                       | 0                      | 0                      | 1,581                  | 0                      | 0                      | 0                      | 0            | 1           | 1      |
| "C"                 | 28                            | Sta. 0+00 to 7+50   | 19     | 2,980   |               |              |         |                   |                   |                |                         |                         |                        |                        |                        |                        |                        |                        |              |             |        |
|                     | 29                            | Sta. 7+50 to 15+50  | 22     | 3,175   |               |              |         |                   |                   |                |                         |                         |                        |                        |                        |                        |                        |                        |              |             |        |
|                     | 30                            | Sta. 15+50 to 23+50 | 36     | 3,175   |               |              |         |                   |                   |                |                         |                         |                        |                        |                        |                        |                        |                        |              |             |        |
|                     | 31                            | Sta. 23+50 to End   | 23     | 2,385   |               |              |         |                   |                   |                |                         |                         |                        |                        |                        |                        |                        |                        |              |             |        |
| Alignment "C" Total |                               |                     | 100    | 11,715  |               | 0            | 0       | 0                 | 0                 | 0              | 0                       | 0                       | 0                      | 0                      | 0                      | 0                      | 0                      | 0                      | 0            | 0           |        |
| "D"                 | 32                            | Sta. 0+00 to End    |        |         |               |              |         |                   |                   | 4              |                         |                         |                        |                        |                        |                        |                        |                        |              | 289         |        |
|                     | Alignment "D" Total           |                     |        | 0       | 0             |              | 0       | 0                 | 0                 | 4              | 0                       | 0                       | 0                      | 0                      | 0                      | 0                      | 0                      | 0                      | 0            | 0           | 0      |
| "E"                 | 33                            | Sta. 0+00 to End    |        |         |               |              |         |                   |                   | 3              |                         |                         |                        |                        |                        |                        |                        |                        |              | 156         |        |
|                     | Alignment "E" Total           |                     |        | 0       | 0             |              | 0       | 0                 | 0                 | 3              | 0                       | 0                       | 0                      | 0                      | 0                      | 0                      | 0                      | 0                      | 0            | 0           | 0      |
| "16/34 N"           | 34                            | Sta. 0+00 to End    |        | 0       |               |              |         |                   |                   |                |                         |                         |                        |                        |                        |                        |                        |                        |              |             |        |
|                     | Alignment "16/34 North" Total |                     |        | 0       | 0             |              | 0       | 0                 | 0                 | 0              | 0                       | 0                       | 0                      | 0                      | 0                      | 0                      | 0                      | 0                      | 0            | 0           | 0      |
| "16/34 S"           | 35                            | Sta. 0+00 to End    |        | 0       |               |              |         |                   |                   |                |                         |                         |                        |                        |                        |                        |                        |                        |              |             |        |
|                     | Alignment "16/34 South" Total |                     |        | 0       | 0             |              | 0       | 0                 | 0                 | 0              | 0                       | 0                       | 0                      | 0                      | 0                      | 0                      | 0                      | 0                      | 0            | 0           | 0      |
| "12/30 N"           | 36                            | Sta. 0+00 to End    |        | 0       |               |              |         |                   |                   |                |                         |                         |                        |                        |                        |                        |                        |                        |              | 0           |        |
|                     | Alignment "12/30 North" Total |                     |        | 0       | 0             |              | 0       | 0                 | 0                 | 0              | 0                       | 0                       | 0                      | 0                      | 0                      | 0                      | 0                      | 0                      | 0            | 0           | 0      |
| "12/30 S"           | 37                            | Sta. 0+00 to End    |        | 0       |               |              |         |                   |                   |                |                         |                         |                        |                        |                        |                        |                        |                        |              |             |        |
|                     | Alignment "12/30 South" Total |                     |        | 0       | 0             |              | 0       | 0                 | 0                 | 0              | 0                       | 0                       | 0                      | 0                      | 0                      | 0                      | 0                      | 0                      | 0            | 0           | 0      |
| TOTAL               |                               |                     | 55,081 | 28,410  | 38            | 2,567        | 1,798   | 1                 | 5                 | 7              | 60                      | 30                      | 30                     | 1,621                  | 30                     | 445                    | 138                    | 519                    | 1            | 2           |        |

AIRPORT WEST DITCH IMPROVEMENTS  
 JACK BROOKS REGIONAL AIRPORT  
 PERIMETER SECURITY FENCE  
 SUMMARY OF STORM SEWER QUANTITIES  
 JEFFERSON COUNTY, TEXAS

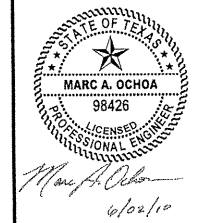

TEXAS REGISTERED  
 ENGINEERING FIRM  
 F-30

**ARCENEUX & GATES**  
 Consulting Engineers, Inc.  
 Engineers Surveyors Planners

LAST PRINTED: Tuesday, June 23, 2009 11:57 AM FROM: Z:\AS\ENGINEERING\PROJECTS\16-34\16-34\SUMMARY OF QUANTITIES.dwg



### SUMMARY OF REMOVAL

| ALIGNMENT           | SHEET NUMBER                  | STATION TO STATION  | REMV OF FEN | REMV PRMTR RD | REMV RC PIPE (48") | REMV RC PIPE (36") | REMV RC PIPE (24") | REMV RC PIPE (18") | REMV EXIST STM INLET |
|---------------------|-------------------------------|---------------------|-------------|---------------|--------------------|--------------------|--------------------|--------------------|----------------------|
|                     |                               |                     | (L.F.)      | (S.Y.)        | (L.F.)             | (L.F.)             | (L.F.)             | (L.F.)             | (L.F.)               |
| "A"                 | 12                            | Sta. 0+00 to 7+50   |             |               | 74                 |                    |                    | 44                 |                      |
|                     | 13                            | Sta. 7+50 to 15+50  |             |               |                    |                    |                    |                    |                      |
|                     | 14                            | Sta. 15+50 to 23+50 |             | 38            |                    | 1,372              |                    |                    |                      |
|                     | 15                            | Sta. 23+50 to 31+50 |             |               |                    |                    |                    | 31                 |                      |
|                     | 16                            | Sta. 31+50 to 39+50 |             |               |                    |                    |                    | 45                 |                      |
|                     | 17                            | Sta. 39+50 to 47+50 |             |               |                    |                    |                    | 72                 |                      |
|                     | 18                            | Sta. 47+50 to 55+50 |             |               |                    |                    |                    |                    |                      |
|                     | 19                            | Sta. 55+50 to 63+50 |             |               |                    |                    |                    |                    |                      |
|                     | 20                            | Sta. 63+50 to 71+50 |             |               |                    |                    |                    |                    |                      |
|                     | 21                            | Sta. 75+00 to 79+50 |             | 1,244         |                    |                    |                    | 28                 |                      |
|                     | 22                            | Sta. 79+50 to 87+50 |             | 1,600         |                    |                    |                    | 84                 |                      |
|                     | 23                            | Sta. 87+50 to 95+50 |             | 1,620         |                    |                    |                    | 42                 |                      |
|                     | 24                            | Sta. 95+50 to 97+01 |             | 212           |                    |                    |                    |                    |                      |
| Alignment "A" Total |                               |                     | 4,676       | 38            | 74                 | 1,372              | 0                  | 346                | 0                    |
| "B"                 | 25                            | Sta. 0+00 to 7+50   |             |               |                    | 1,372              |                    |                    | 1                    |
|                     | 26                            | Sta. 7+50 to 14+50  |             |               |                    |                    |                    |                    |                      |
|                     | 27                            | Sta. 14+50 to 15+93 |             |               |                    |                    |                    |                    |                      |
| Alignment "B" Total |                               |                     | 0           | 0             | 0                  | 1,372              | 0                  | 0                  | 1                    |
| "C"                 | 28                            | Sta. 0+00 to 7+50   |             |               | 22                 | △                  |                    |                    |                      |
|                     | 29                            | Sta. 7+50 to 15+50  |             |               | 39                 | △                  |                    |                    |                      |
|                     | 30                            | Sta. 15+50 to 23+50 |             |               |                    |                    |                    | 32                 | △                    |
|                     | 31                            | Sta. 23+50 to End   |             |               |                    |                    | 50                 | △                  |                      |
| Alignment "C" Total |                               |                     | 0           | 0             | 61                 | △                  | 0                  | 50                 | △                    |
| "D"                 | 32                            | Sta. 0+00 to End    |             |               |                    |                    |                    |                    |                      |
|                     | Alignment "D" Total           |                     |             | 0             | 0                  | 0                  | 0                  | 0                  | 0                    |
| "E"                 | 33                            | Sta. 0+00 to End    |             |               |                    |                    | 25                 |                    |                      |
|                     | Alignment "E" Total           |                     |             | 0             | 0                  | 0                  | 0                  | 25                 | 0                    |
| "16/34 N"           | 34                            | Sta. 0+00 to End    |             |               |                    |                    |                    |                    |                      |
|                     | Alignment "16/34 North" Total |                     |             | 0             | 0                  | 0                  | 0                  | 0                  | 0                    |
| "16/34 S"           | 35                            | Sta. 0+00 to End    |             |               |                    |                    |                    |                    |                      |
|                     | Alignment "16/34 South" Total |                     |             | 0             | 0                  | 0                  | 0                  | 0                  | 0                    |
| "12/30 N"           | 36                            | Sta. 0+00 to End    |             |               |                    |                    |                    |                    |                      |
|                     | Alignment "12/30 North" Total |                     |             | 0             | 0                  | 0                  | 0                  | 0                  | 0                    |
| "12/30 S"           | 37                            | Sta. 0+00 to End    |             |               |                    |                    |                    |                    |                      |
|                     | Alignment "12/30 South" Total |                     |             | 0             | 0                  | 0                  | 0                  | 0                  | 0                    |
| TOTAL               |                               |                     | 4,676       | 38            | 135                | △                  | 2,744              | 75                 | △                    |

### SUMMARY OF MICELLANEOUS

| DESCRIPTION                   | UNIT | QUANTITY |
|-------------------------------|------|----------|
| FERTILIZING                   | AC.  | 82 △     |
| VEG WATERING                  | AC.  | 82 △     |
| TEMP DAMS                     | EACH | 8        |
| PERM BRDCST SEEDING (WET APP) | AC.  | 82 △     |
| MOBILIZATION                  | L.S. | 1        |

|             |
|-------------|
| SHEET       |
| 5           |
| NO.         |
| DATE        |
| SCALE       |
| JOB NO.     |
| DESIGNED BY |
| CHECKED BY  |
| DRAWN BY    |
| APPROV.     |
| REVISION    |
| APPENDIX #  |
| J.M.W.      |

AIRPORT WEST DITCH IMPROVEMENTS  
 JACK BROOKS REGIONAL AIRPORT  
 PERIMETER SECURITY FENCE  
 SUMMARY OF REMOVAL  
 JEFFERSON COUNTY, TEXAS



Marc A. Ochoa  
6/02/10

TEXAS REGISTERED ENGINEERING FIRM  
F-30

**ARCENEUX & GATES**  
 Consulting Engineers, Inc.  
 Engineers Surveyors Planners



**ARCENEUX & GATES**  
 CONSULTING ENGINEERS, INC.  
 FORT ARTHUR, TEXAS

LAST PRINTED: Tuesday, June 23, 2010 3:14:27 PM FROM: Z:\ARC\ENGINEERING\PROJECTS\1208\ARC\1208\FE\1208\_SUMMARY\_OF\_REMOVAL.dwg

LAST PRINTED: Thursday, June 20, 2006 3:42:51 PM FROM: C:\MAG\ENGINEERING\PROJECTS\NEF\2006\WSS\NETS\PROJECT LOCATION MAP.dwg

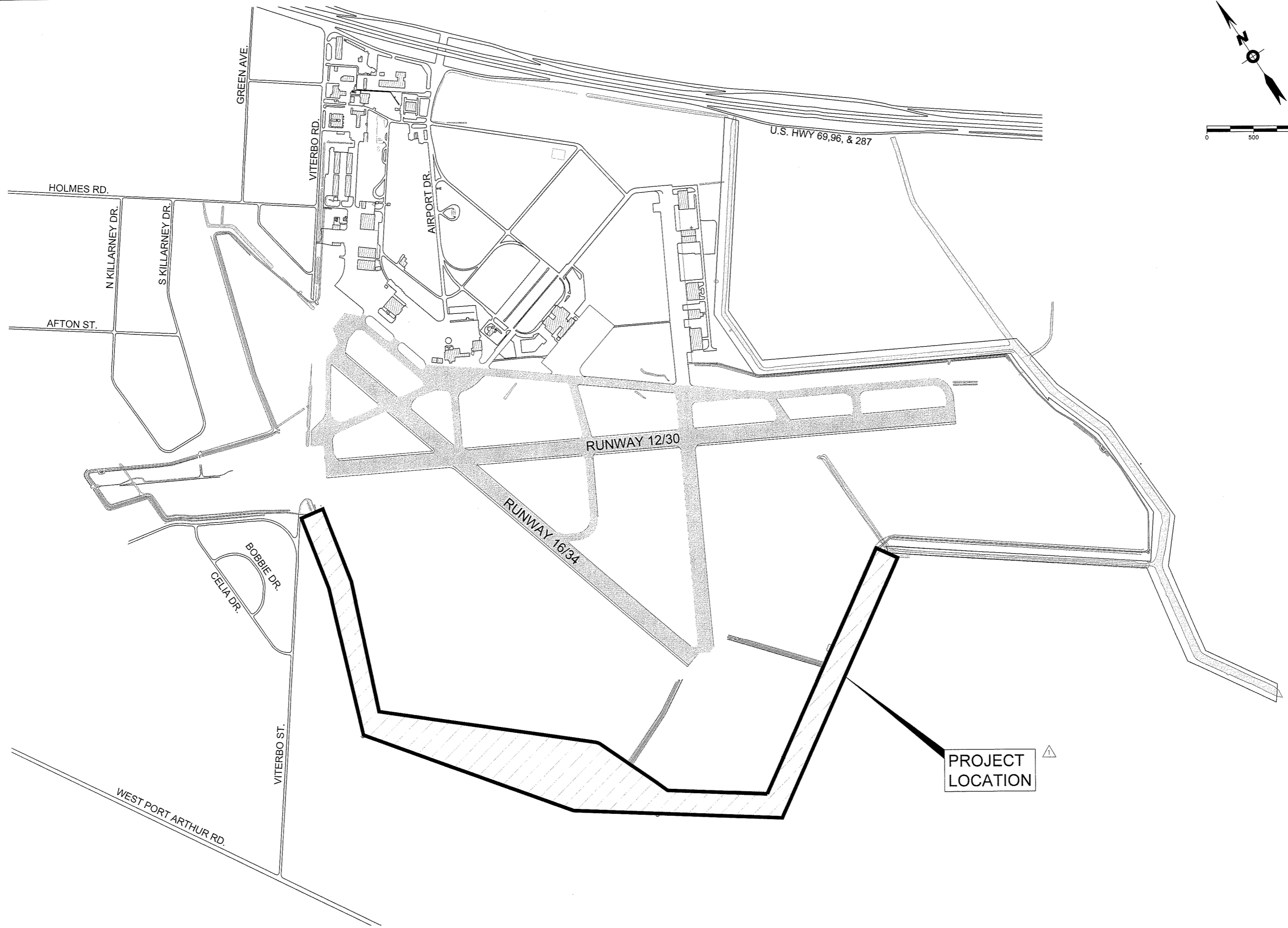

PROJECT LOCATION

|                           |  |                     |  |
|---------------------------|--|---------------------|--|
| SHEET<br><b>6</b>         |  | DRAWN BY: A.R.C.    |  |
| NO. 1                     |  | CHECKED BY: J.M.W.  |  |
| DATE: MAY 2010            |  | DESIGNED BY: M.A.O. |  |
| JOB NO.: 88-120           |  | SCALE: 1"=1000'     |  |
| ADDITIONAL #2<br>REVISION |  | DATE: 6/1/10        |  |
| APPROV.                   |  | J.M.W.              |  |

**AIRPORT WEST DITCH IMPROVEMENTS  
JACK BROOKS REGIONAL AIRPORT  
PROJECT LOCATION MAP**

JEFFERSON COUNTY, TEXAS

TEXAS REGISTERED ENGINEERING FIRM  
F-30

**ARCENEUX & GATES**  
Consulting Engineers, Inc.  
Engineers - Surveyors - Planners

LAST PRINTED: Tuesday, June 29, 2010 3:42:51 PM FROM: Z:\AEC\ENGINEERING\AEC PROJECTS\AEC-FINAL\AEC\DWG\SSHEETS - FILL AREA LAYOUT.dwg

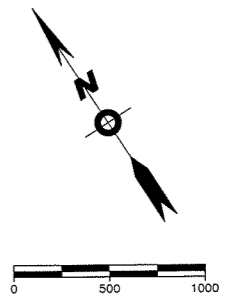
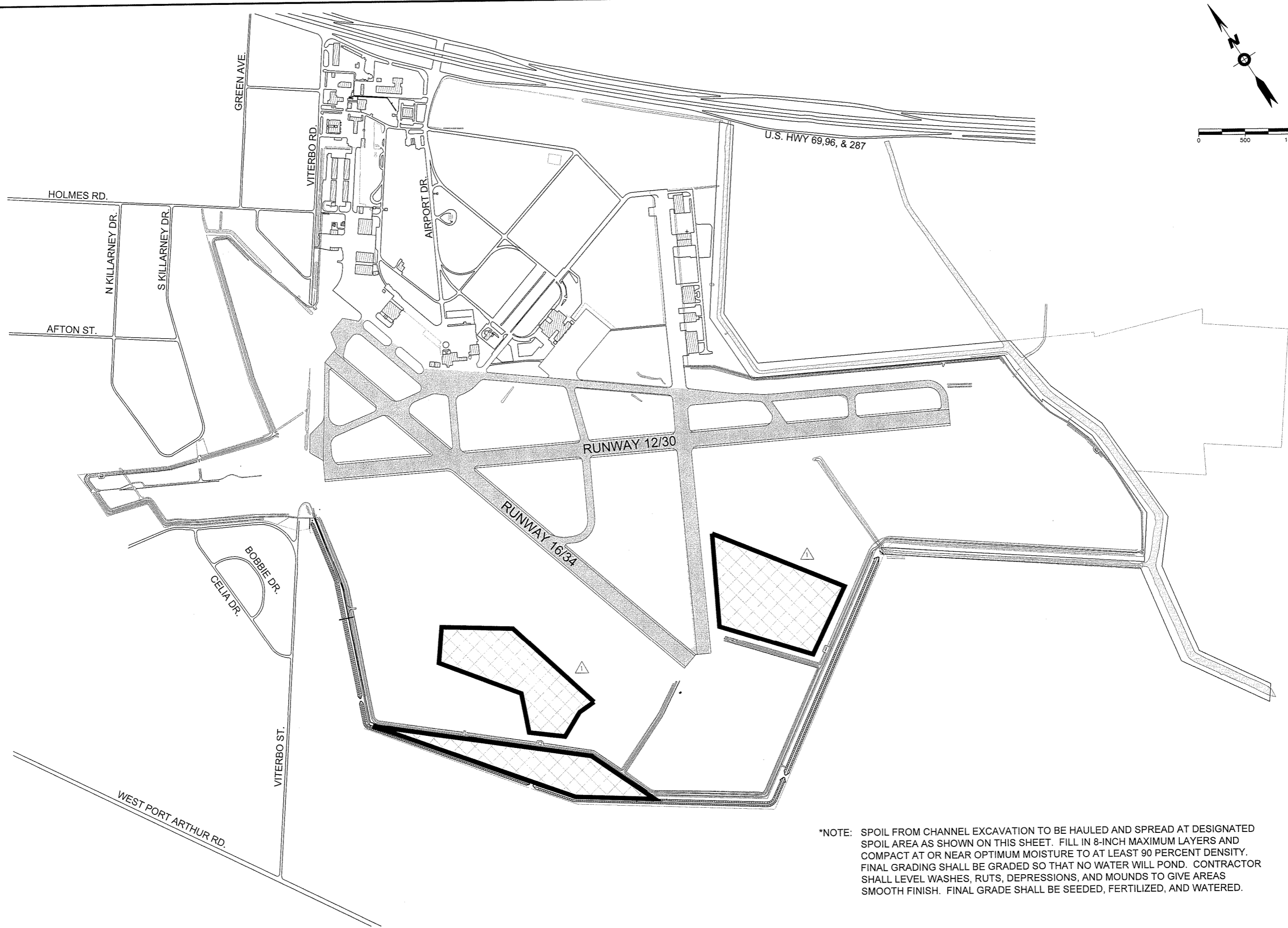

\*NOTE: SPOIL FROM CHANNEL EXCAVATION TO BE HAULED AND SPREAD AT DESIGNATED SPOIL AREA AS SHOWN ON THIS SHEET. FILL IN 8-INCH MAXIMUM LAYERS AND COMPACT AT OR NEAR OPTIMUM MOISTURE TO AT LEAST 90 PERCENT DENSITY. FINAL GRADING SHALL BE GRADED SO THAT NO WATER WILL POND. CONTRACTOR SHALL LEVEL WASHES, RUTS, DEPRESSIONS, AND MOUNDS TO GIVE AREAS SMOOTH FINISH. FINAL GRADE SHALL BE SEEDED, FERTILIZED, AND WATERED.

|                   |        |                     |                    |
|-------------------|--------|---------------------|--------------------|
| SHEET<br><b>7</b> |        | DESIGNED BY: M.A.O. | CHECKED BY: J.M.W. |
| NO.               | DATE   | DESIGNED BY: M.A.O. | CHECKED BY: J.M.W. |
| 1                 |        |                     |                    |
| 2                 | 6/7/10 |                     |                    |
| 3                 |        |                     |                    |
| 4                 |        |                     |                    |

**AIRCRAFT WEST DITCH IMPROVEMENTS**  
**JACK BROOKS REGIONAL AIRPORT**  
**FILL AREA LAYOUT**  
 JEFFERSON COUNTY, TEXAS

Marc A. Ochoa  
6/02/10

TEXAS REGISTERED ENGINEERING FIRM  
F-30

**ARCENEUX & GATES**  
Consulting Engineers, Inc.  
Engineers Surveyors Planners

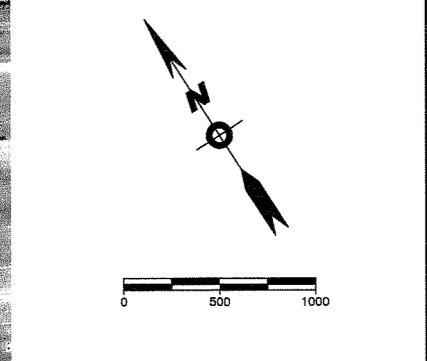

|       |        |          |         |
|-------|--------|----------|---------|
| SHEET |        | 7A       |         |
| 1     | 2      | 3        | 4       |
| NO.   | DATE   | REVISION | APPROV. |
| 1     | 6/7/10 |          | J.M.W.  |
| 2     |        |          |         |
| 3     |        |          |         |
| 4     |        |          |         |

AIRPORT WEST DITCH IMPROVEMENTS  
 JACK BROOKS REGIONAL AIRPORT  
 CLEARING AND GRUBBING LAYOUT  
 JEFFERSON COUNTY, TEXAS

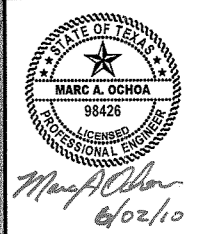

TEXAS REGISTERED  
 ENGINEERING FIRM  
 F-30

**ARCENEUX & GATES**  
 Consulting Engineers, Inc.  
 Engineers Surveyors Planners

NOTE:  
 CONTRACTOR SHALL SPREAD ALL CUT UP MATERIALS WITHIN THE AIRPORT PROPERTY AND OUTSIDE OF THE PROPOSED EASEMENT AS DIRECTED BY THE AIRPORT REPRESENTATIVES

LAST PRINTED: Tuesday, June 29, 2008 11:42:51 PM FROM: Z:\AEC ENGINEERING\PROJECTS\1001\1001\1001\1001\1001\CLEARING AND GRUBBING\1001.dwg

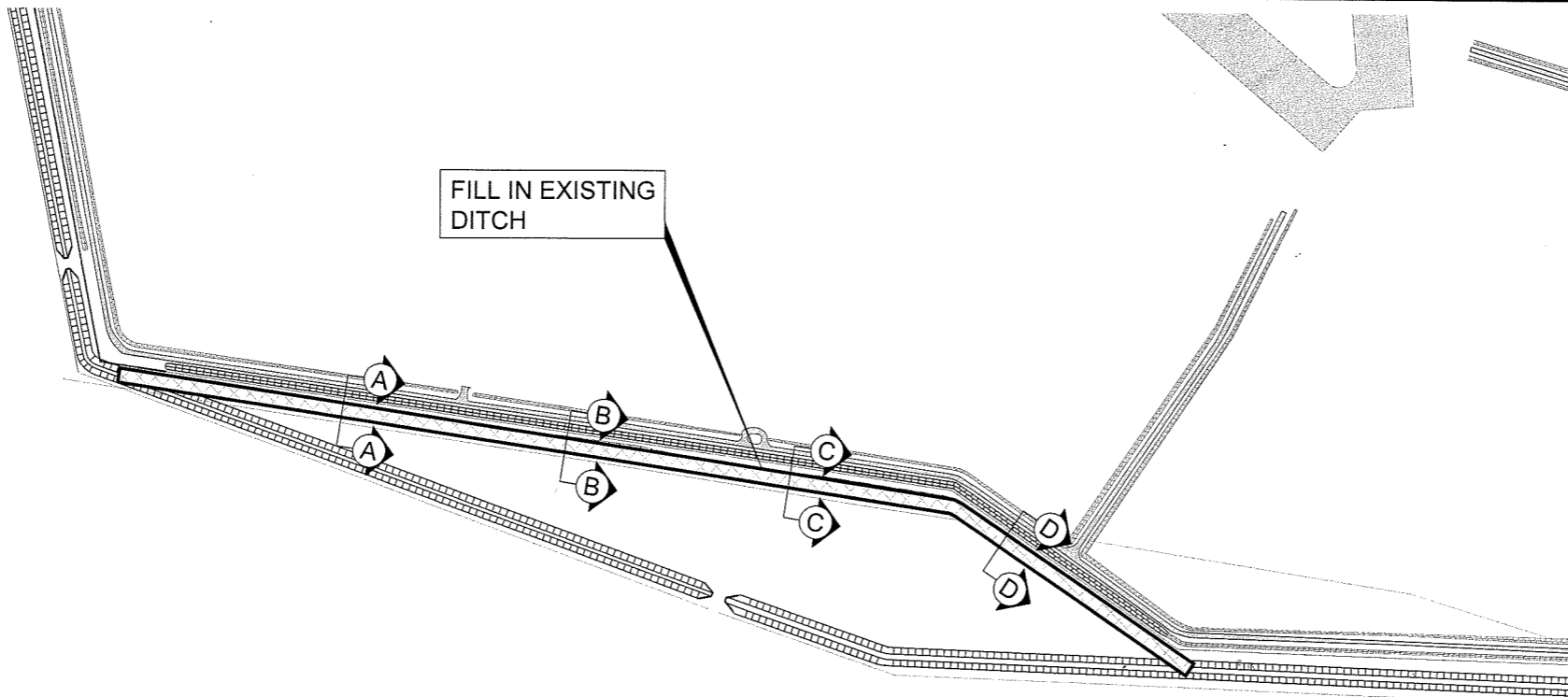

**NOTE:**  
 CONTRACTOR SHALL CLEAR ALL VEGETATION WITHIN  
 AREAS OF EMBANKMENT AND OUTSIDE OF THE PROPOSED  
 EASEMENT TO A MINIMUM OF TWO FEET BELOW FINAL  
 GRADE.

SCALE: H. 1"=80' V. 1"=8'

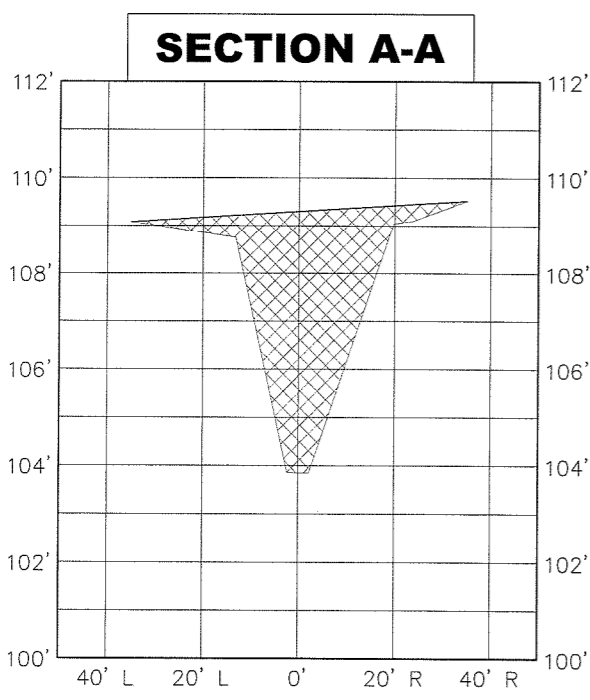

| CROSS SECTION INFORMATION |                |
|---------------------------|----------------|
| Cut Area                  | 0.00 SQ. FT.   |
| Fill Area                 | 116.63 SQ. FT. |

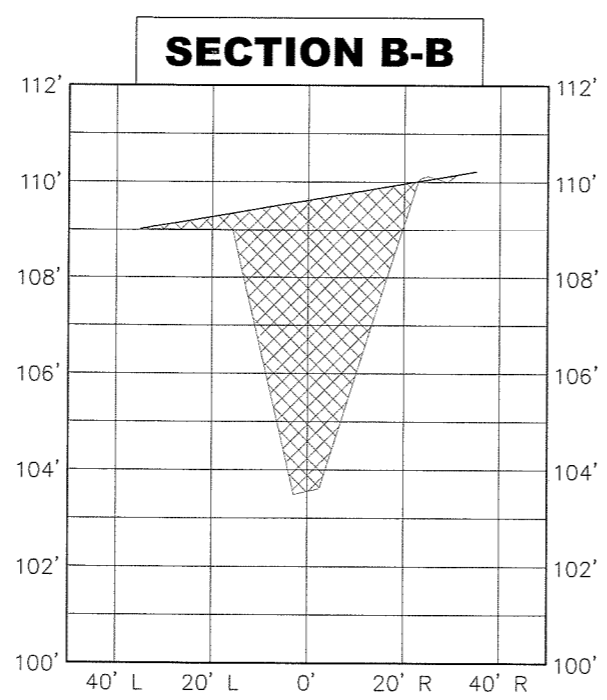

| CROSS SECTION INFORMATION |                |
|---------------------------|----------------|
| Cut Area                  | 0.17 SQ. FT.   |
| Fill Area                 | 139.06 SQ. FT. |

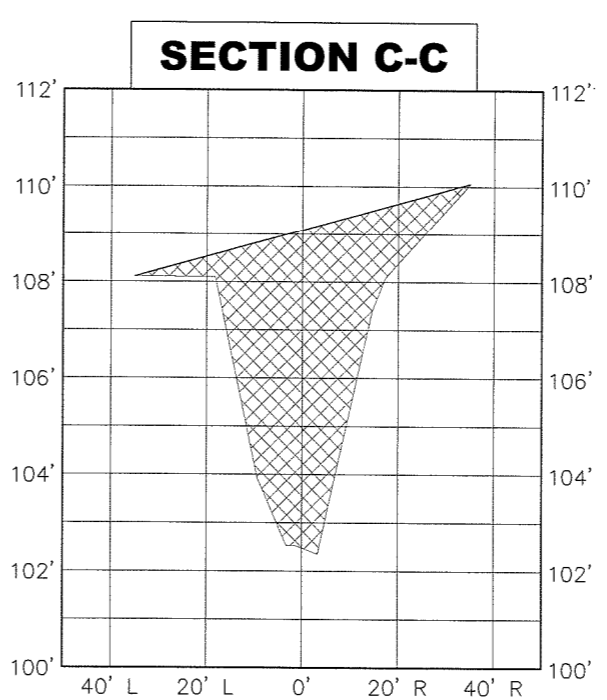

| CROSS SECTION INFORMATION |                |
|---------------------------|----------------|
| Cut Area                  | 0.00 SQ. FT.   |
| Fill Area                 | 174.04 SQ. FT. |

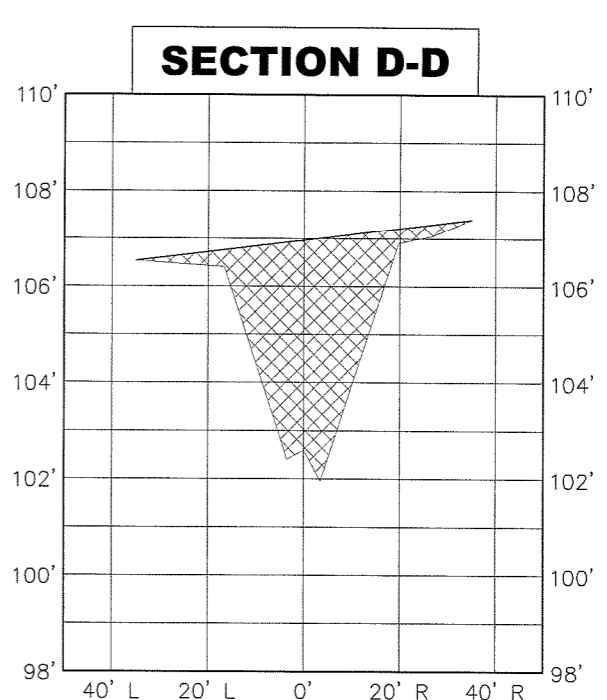

| CROSS SECTION INFORMATION |                |
|---------------------------|----------------|
| Cut Area                  | 0.00 SQ. FT.   |
| Fill Area                 | 113.63 SQ. FT. |

LAST PRINTED: Tuesday, June 20, 2010 3:14:27 PM FROM: Z:\MAG ENGINEERING\PROJECTS\A-1\0909\DWG\EXISTING DITCH FILL ADDENDUM 1.dwg

|   |  |
|---|--|
| SHEET<br><b>7B</b>  | DRAWN BY: A.R.C.<br>CHECKED BY: J.M.W. |
| ADDENDUM #2<br>REVISION   | SCALE: 1"=500'                         |
| NO. DATE  | DESIGNED BY: M.A.O.                    |
| 4 3 2 1   | DATE: MAY 2010<br>JOB NO.: 05-720      |
| <b>AIRPORT WEST DITCH IMPROVEMENTS</b><br><b>JACK BROOKS REGIONAL AIRPORT</b><br><b>EXISTING DITCH FILL LOCATION</b><br>JEFFERSON COUNTY, TEXAS |  |
|   |  |
| TEXAS REGISTERED<br>ENGINEERING FIRM<br><b>F-30</b>   |  |
| <b>ARCENEUX &amp; GATES</b><br>Consulting Engineers, Inc.<br>Engineers Surveyors Planners   |  |
|   |  |

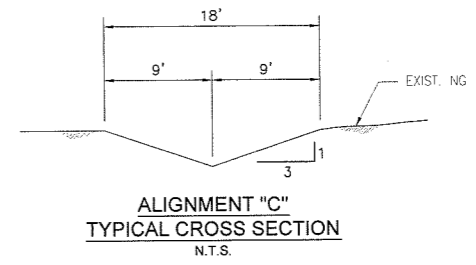
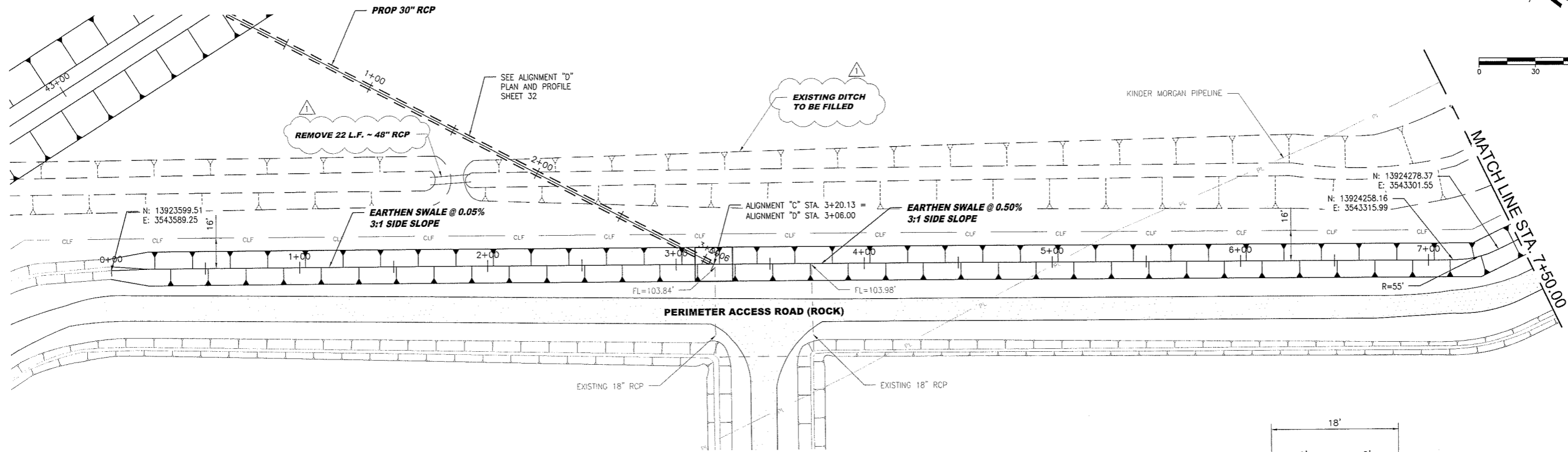
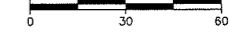
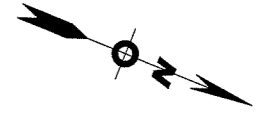

**ALIGNMENT "C" STA. 0+00 TO 7+50**

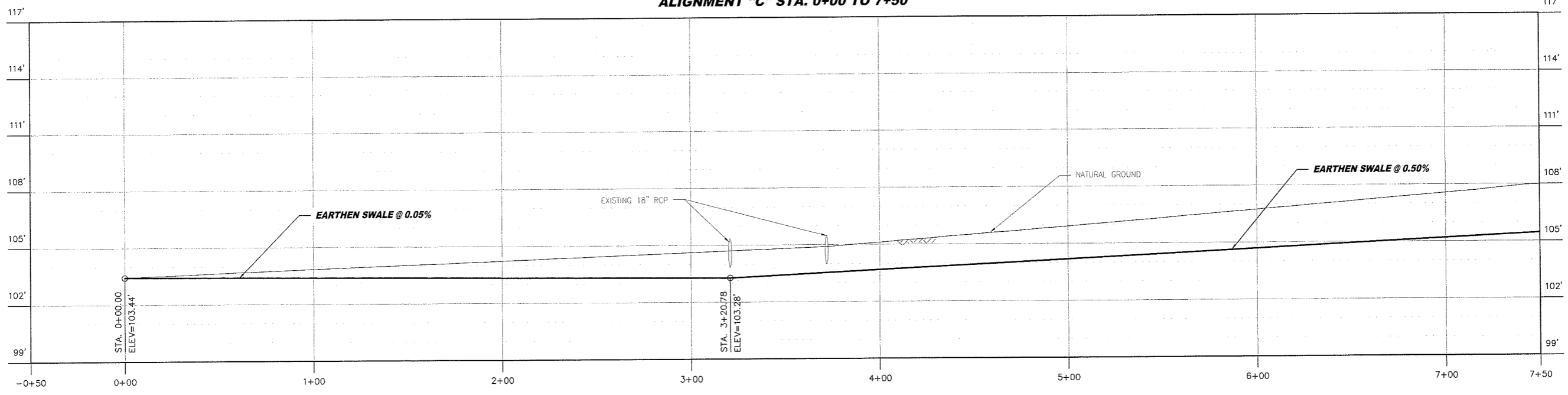

**AIRPORT WEST DITCH IMPROVEMENTS**  
**JACK BROOKS REGIONAL AIRPORT**  
**ALIGNMENT "C" PLAN AND PROFILE**  
**STA. 0+00 TO 7+50**  
**JEFFERSON COUNTY, TEXAS**

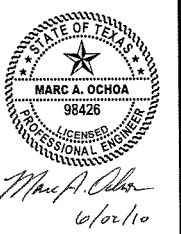

TEXAS REGISTERED  
ENGINEERING FIRM  
★ F-30 ★

**ARCENEUX & GATES**  
 Consulting Engineers, Inc.  
 Engineers Surveyors Planners



LAST PRINTED: Tuesday, June 20, 2006 3:42:21 PM FROM: C:\MSD\ENGINEERING\PROJECTS\REF-ROAD\DRAWINGS\SETS\SUB-ALIGNMENT C\PLAN AND PROFILE.dwg

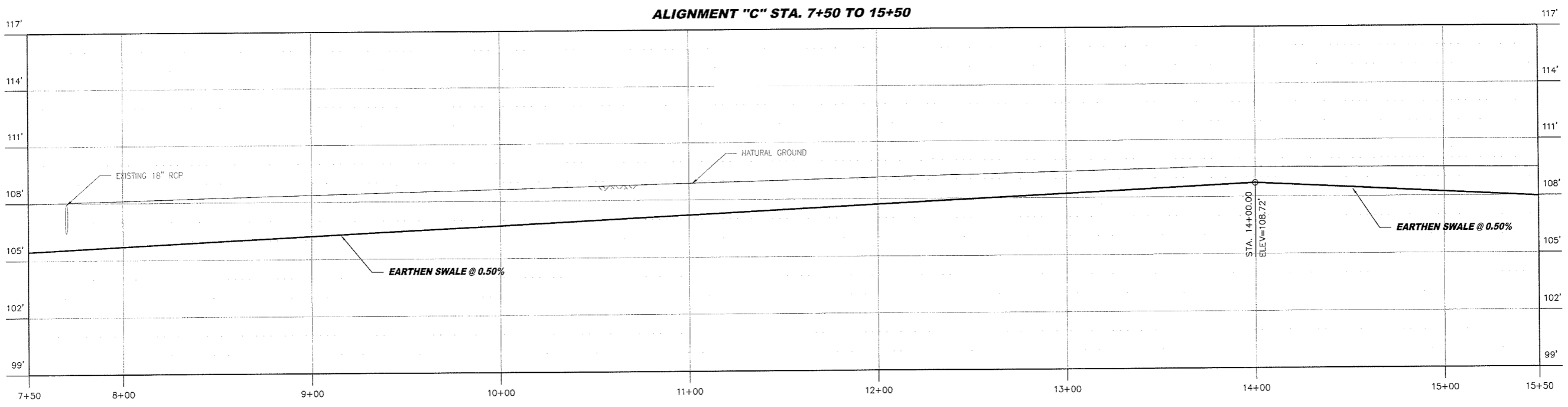
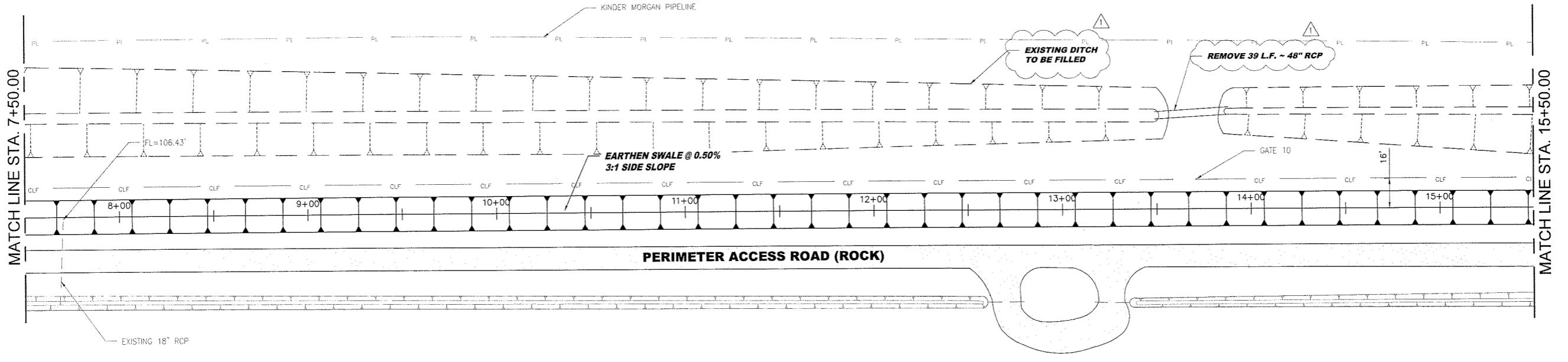
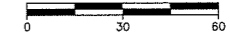
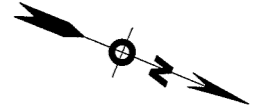

**AIRPORT WEST DITCH IMPROVEMENTS**  
**JACK BROOKS REGIONAL AIRPORT**  
**ALIGNMENT "C" PLAN AND PROFILE**  
**STA. 7+50 TO 14+50**  
 JEFFERSON COUNTY, TEXAS



TEXAS REGISTERED  
 ENGINEERING FIRM  
 F-30

**ARCENBAUX & GATES**  
 Consulting Engineers, Inc.  
 Engineers Surveyors Planners



|     |        |             |         |
|-----|--------|-------------|---------|
| NO. | DATE   | REVISION    | APPROV. |
| 4   |        |             |         |
| 3   |        |             |         |
| 2   | 6/7/10 | ADDENDUM #2 | J.M.W.  |
| 1   |        |             |         |

DATE: MAY 2010  
 SCALE: H. 1"=30' V. 1"=3'  
 DESIGNED BY: M.A.O.  
 CHECKED BY: J.M.W.

LAST PRINTED: Tuesday, June 28, 2008 2:14:21 PM FROM: Z:\A&G\ENGINEERING\GAG\PROJECTS\AIP-1204\DWG\MSHSET29.DWG - ALIGNMENT C PLAN AND PROFILE.dwg

|     |        |             |
|-----|--------|-------------|
| NO. | DATE   | REVISION    |
| 1   | 9/1/10 | ADDITION #2 |
| 2   |        |             |
| 3   |        |             |
| 4   |        |             |

DATE: MAY 2010  
 DESIGNED BY: M.A.O.  
 DRAWN BY: A.B.C.  
 CHECKED BY: J.M.W.

**AIRPORT WEST DITCH IMPROVEMENTS  
 JACK BROOKS REGIONAL AIRPORT  
 ALIGNMENT "C" PLAN AND PROFILE  
 STA. 15+50 TO 23+50  
 JEFFERSON COUNTY, TEXAS**

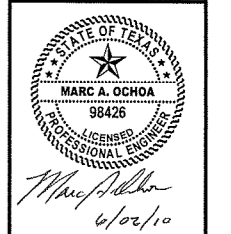

TEXAS REGISTERED  
 ENGINEERING FIRM  
 F-30

**ARCENEAUX & GATES**  
 Consulting Engineers, Inc.  
 Engineers Surveyors Planners

**ARCENEAUX & GATES**  
 Consulting Engineers, Inc.  
 1401 W. 14th Street, Suite 100  
 Fort Worth, Texas 76104

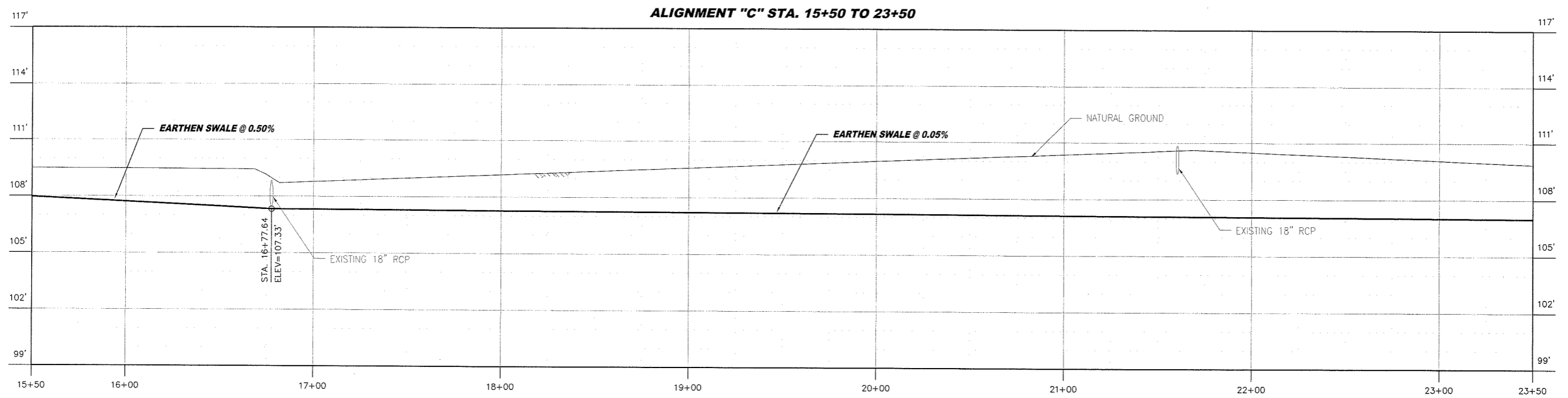
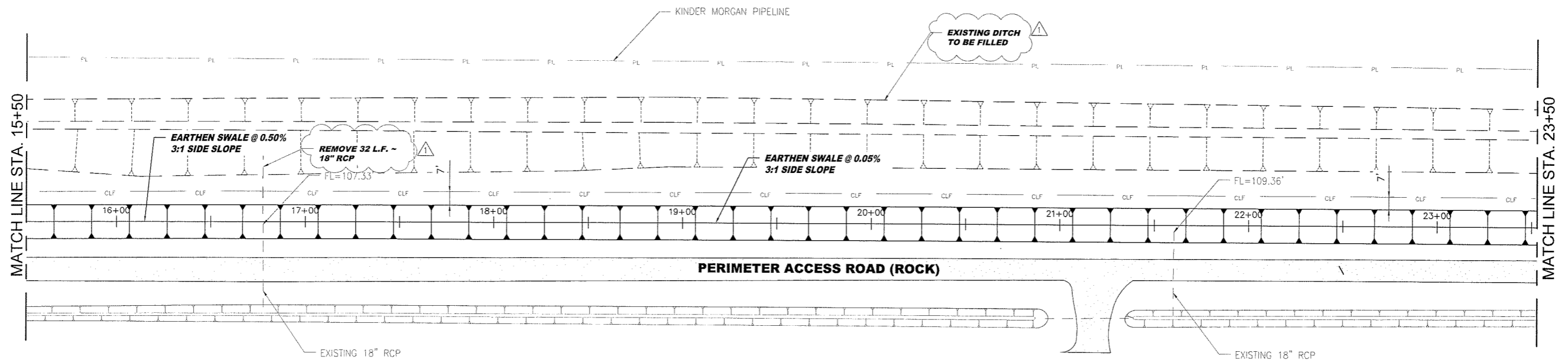
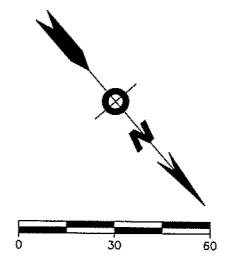

LAST PRINTED: Tuesday, June 20, 2011 11:52 AM FROM: Z:\ASAC\ENGINEERING\PROJECTS\2010\ARCENEAUX\GATES\ALIGNMENT C PLAN AND PROFILE.dwg



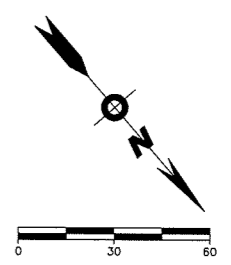

|       |        |             |             |
|-------|--------|-------------|-------------|
| SHEET |        | 31          |             |
| NO.   | DATE   | REVISION    | DESIGNED BY |
| 4     |        |             | M.A.O.      |
| 3     |        |             | J.M.V.      |
| 2     | 6/7/10 | ADDITION #1 | J.M.V.      |
| 1     |        |             | A.R.C.      |

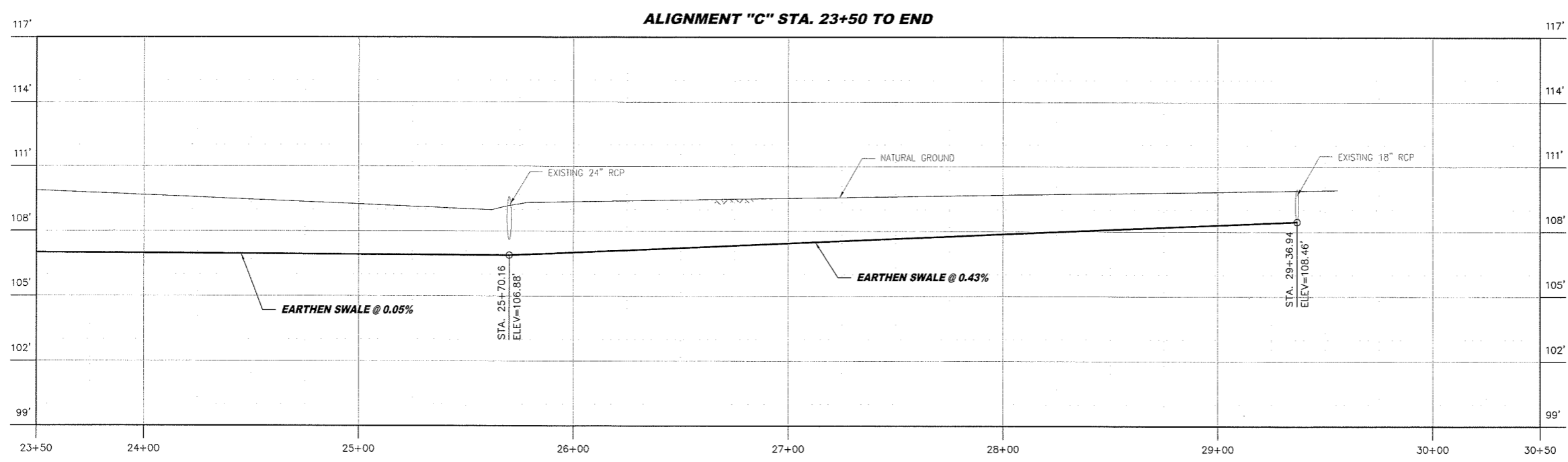
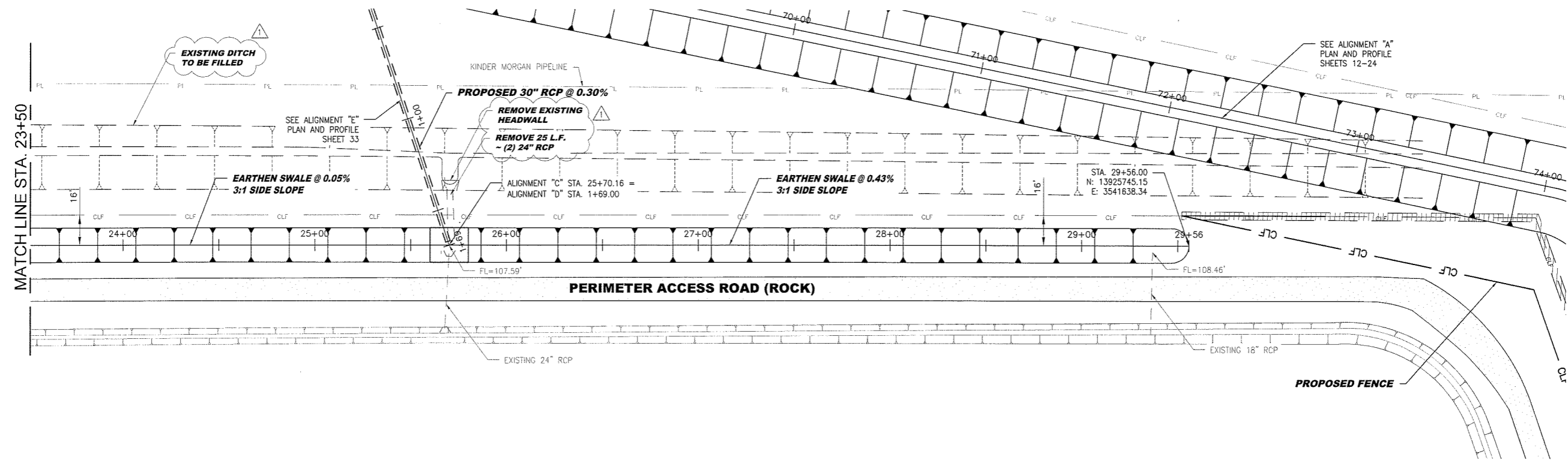

**AIRPORT WEST DITCH IMPROVEMENTS**  
**JACK BROOKS REGIONAL AIRPORT**  
**ALIGNMENT "C" PLAN AND PROFILE**  
**STA. 23+50 TO END**  
**JEFFERSON COUNTY, TEXAS**

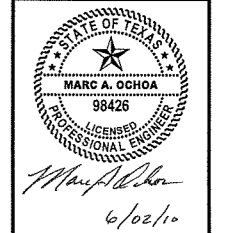

TEXAS REGISTERED  
ENGINEERING FIRM  
★ F-30 ★

**ARCENEUX & GATES**  
Consulting Engineers, Inc.  
Engineers Surveyors Planners

**ARCENEUX & GATES**  
CONSULTING ENGINEERS, INC.  
FORT WORTH, TEXAS

LAST PRINTED Tuesday, June 20, 2010 3:42:27 PM P:\3101\_24102\ENGINEERING\PROJECTS\24102\WORKSHEETS\24102 - ALIGNMENT C PLAN AND PROFILE.dwg