



JEFFERSON COUNTY PURCHASING DEPARTMENT

Deborah L. Clark, Purchasing Agent

1149 Pearl Street, Beaumont, TX 77701 409-835-8593 Fax 409-835-8456

LEGAL NOTICE Advertisement for Request for Proposal

September 17, 2012

Notice is hereby given that sealed proposals will be accepted by the Jefferson County Purchasing Department for RFP 12-032/JW, Re-bid for Term Contract for Automated Teller Machines (ATM) Installation and Operation for Jefferson County. Specifications for this project may be obtained from <http://www.co.jefferson.tx.us>, or by calling 409-835-8593.

Proposals are to be addressed to the Purchasing Agent with the proposal number and name marked on the outside of the envelope. Respondents shall forward an original and five (5) copies of their proposal to the address shown below. Late proposals will be rejected as non-responsive. Proposals will be publicly opened and only the firm name will be read aloud in the Jefferson County Commissioners' Courtroom at the time and date below. Proposals shall be opened in a manner that avoids disclosure of the contents to competing Respondents and maintains the confidentiality of the proposals during negotiations. Proposals will be open for public inspection after the award of the contract, except for trade secrets and confidential information. Respondents are invited to attend the sealed proposal opening.

PROPOSAL NAME: Re-bid for Term Contract for Automated Teller Machines
(ATM) Installation and Operation for Jefferson County
PROPOSAL NO: RFP 12-032/JW
DUE DATE/TIME: 11:00 AM, October 30, 2012
MAIL OR DELIVER TO: Jefferson County Purchasing Department
1149 Pearl Street, 1st Floor
Beaumont, Texas 77701

Any questions relating to these requirements should be directed to Jamey West, Contract Specialist at 409-835-8593.

All interested firms are invited to submit a proposal in accordance with the terms and conditions stated in this proposal.

RESPONDENTS ARE STRONGLY ENCOURAGED TO CAREFULLY READ THE ENTIRE INVITATION.

Deborah L. Clark
Purchasing Agent
Jefferson County, Texas

Publish: Beaumont Enterprise & Port Arthur News – September 19 & 26, 2012

RFP 12-032/JW
Re-bid for Term Contract for Automated Teller Machines (ATM)
Installation and Operation for Jefferson County

TABLE OF CONTENTS

Table of Contents.....	2
Overview of RFP.....	4
Proposal Submittal Checklist.....	5
1. Introduction to Respondents	6
1.1 Vendor Instructions	6
1.2 Governing Law	6
1.3 Ambiguity, Conflict, or Other Errors in the RFP	6
1.4 Notification of Most Current Address	6
1.5 Proposal Preparation Cost	7
1.6 Signature of Proposal.....	7
1.7 Economy of Presentation	7
1.8 Proposal Obligation	7
1.9 Incorporation by Reference and Precedence	7
1.10 Governing Forms.....	8
1.11 Implied Requirements.....	8
1.12 Compliance with RFP Specifications	8
1.13 Evaluation.....	8
1.14 Withdrawal of Proposal.....	8
1.15 Award	8
1.16 Ownership of Proposal	9
1.17 Disqualification of Respondent	9
1.18 Contractual Development.....	9
1.19 Assignment.....	9
1.20 Contract Obligation.....	9
1.21 Termination	9
1.22 Inspections	10
1.23 Testing.....	10
1.24 Loss, Damage, or Claim	10
1.25 Waiver of Subrogation	10
1.26 Conflict of Interest	10
1.27 Acknowledgment of Insurance Requirements	10
1.28 Delivery of Proposals.....	11
1.29 Questions	11

2. Response Format	12
2.1 Introduction	12
2.2 Organization of Proposal Contents	12
2.3 Transmittal Letter	12
2.4 Executive Summary	13
2.5 Table of Contents	13
2.6 Respondent Identifying Information	13
2.7 Proposed Agreement	14
2.8 Conflict of Interest	14
3. Proposal Submittal	15
4. Scope of Services	16
4.1 Background	16
4.2 Current and Possible Locations for ATMs	16
4.3 Security Requirements	17
4.4 Installation Requirements	17
4.5 Service Requirements	18
4.6 ADA Requirements	18
4.7 Definitions	19
5. Project Requirements	21
5.1 Respondent Experience	21
6. Proposal Evaluation and Selection Process	22
6.1 Introduction	22
6.2 Cost Proposal	22
6.3 Proposal Evaluation and Selection	22
6.4 Evaluation Criteria	22
Appendix A. Cost Proposal	23
Appendix B. Vendor References	24
Appendix C. Signature Page	25
Appendix D. Conflict of Interest Questionnaire	26
Appendix E. Good Faith Effort (GFE)	28
Appendix F. Notice of Intent (NOI)	29
Appendix G. Subcontracting Participating Declaration Form (HUB)	30
Appendix H. Residence Certification/Tax Form	34
Appendix I. Bid Affidavit	35

RFP 12-032/JW
Re-bid for Term Contract for Automated Teller Machines (ATM)
Installation and Operation for Jefferson County
BIDS DUE: 11:00 AM, OCTOBER 30, 2012

JEFFERSON COUNTY WILL NOT BE RESPONSIBLE
FOR UNMARKED OR IMPROPERLY MARKED ENVELOPES.

It is intended that the successful respondent will install and operate automated teller machines (ATMs) for an initial term of one (1) year, with four (4) potential renewal terms of one (1) year each. Installation and Operation entails the installation, replenishment of funds, maintenance, and repairs of Automated Teller Machines.

There is no expressed or implied obligation for Jefferson County to reimburse responding bidders for any expense incurred in preparing bid in response to this request and Jefferson County will not reimburse bidders for these expenses.

All Proposals must be received in the Purchasing Department before the opening, October 30, 2012 at 11:00 AM. Proposals received after the date and time above will be considered void and unacceptable and returned to the Respondent unopened. Jefferson County is not responsible for lateness or non-delivery of mail, carrier, etc., and the date/time stamp in the Purchasing Office shall be the official time of receipt.

Please take note of the following Jefferson County Holidays:

January 2, 2012	September 3, 2012
January 16, 2012	November 12, 2012
February 20, 2012	November 22 & 23, 2012
April 6, 2012	December 24 & 25, 2012
May 28, 2012	January 1, 2013
July 4, 2012	

Facsimile Transmittals Shall Not Be Accepted.

The enclosed **Request for Proposals** and accompanying **Specifications and Submittal Checklist** must be completed prior to submission. Failure to complete forms/affidavits may render your proposal null and void. Proposals will be opened and the names of Respondents read aloud in the Commissioners' Courtroom, Fourth Floor, 1149 Pearl Street, Beaumont, Texas.

In the event the Commissioners' Courtroom is in use at time of opening, proposals will be opened in the Conference Room of the Jefferson County Judge.

Hours for the Purchasing Department are 8:00 AM – 5:00 PM central time, Monday - Friday.

PROPOSAL SUBMITTAL CHECKLIST

The Respondent's attention is especially called to the items listed below, which must be submitted in full as part of the proposal.

Failure to submit any of the documents listed below as a part of your proposal, or failure to acknowledge any addendum in writing with your proposal, or submitting a proposal on any condition, limitation, or provision not officially invited in this Request for Proposal (RFP) may cause for rejection of the proposal.

Respondent shall check each box indicating compliance.

THIS CHECKLIST MUST BE SUBMITTED AS PART OF YOUR PACKAGE

- Cover sheet identifying the contract/project being proposed, the name and address of the Respondent, the date of the proposal, and the telephone and facsimile numbers of Respondent.
- An acknowledgment and/or response to each section of the proposal.
- Form of business (e.g., corporation, sole proprietorship, partnership); if corporation the date and state of incorporation.
- Identification of three (3) entities for which the Respondent is providing or has provided automated teller machines (ATMs) of the type requested, including the name, position, and telephone number of a contact person at each entity.
- Identification of all legal claims, demands, contracts terminated or lawsuits filed, threatened, or pending against the Respondent and/or its principal/officers for the last three (3) years, as well as identification of any administrative actions or warnings taken or issued by any federal, state, or local governmental agency to Respondent and/or its principals/officers with regard to the provision of the same or similar service as covered by this RFP, or the payment of moneys under the terms of any agreement(s) relating to such services.
- Same contract with compensation sections blank.
- One (1) original and five (5) copies of the proposal should be mailed to or delivered no later than **11:00 AM, October 30, 2012**, to the Jefferson County Purchasing Department, 1149 Pearl Street, First Floor, Beaumont, TX 77701.

PLEASE READ THE "PROPOSAL SUBMITTAL CHECKLIST" INCLUDED IN THIS PACKAGE.

Company

Telephone Number

Address

Fax Number

Authorized Representative (Please print)

Title

Authorized Signature

Date

1. INTRODUCTION TO RESPONDENTS

This Request for Proposal (RFP) is to receive proposals from qualified firms regarding services for the installation and operation of Automated Teller Machines (ATMs) in Jefferson County buildings.

The following items are provided as general information and specifications as required by the Jefferson County Purchasing Department.

1.1 VENDOR INSTRUCTIONS

Read the document carefully. Follow all instructions. You are responsible for fulfilling all requirements and specifications. Be sure you have a clear understanding of the proposal.

General Requirements apply to all advertised requests for proposals; however, these may be superseded, whole or in part, by the **Scope of Services, Guidelines and Specifications, Requested Responses and Information, or other data contained herein.** Be sure your proposal package is complete.

1.2 GOVERNING LAW

Respondent is advised that these requirements shall be fully governed by the laws of the State of Texas and that Jefferson County may request and rely on advice, decisions, and opinions of the Attorney General of Texas and the Jefferson County Attorney concerning any portion of these requirements.

1.3 AMBIGUITY, CONFLICT, OR OTHER ERRORS IN THE RFP

If Respondent discovers any ambiguity, conflict, discrepancy, omission or other error in the RFP, Respondent shall immediately notify Jefferson County of such error in writing and request modification or clarification of the document. Modifications will be made by issuing Addenda. Written notice will be given to all parties who have been furnished with the RFP without divulging the source of the request for the same. If the Respondent fails to notify Jefferson County prior to the date and time fixed for submission of proposals of an error or ambiguity in the RFP known to Respondent, or an error or ambiguity that reasonably should have been known to Respondent, then Respondent shall not be entitled to compensation or additional time by reason of the error or ambiguity or its later resolution.

Jefferson County may also modify the RFP, no later than 48 hours prior to the date and time fixed for submission of proposals, by issuance of an Addendum to all parties who have received the RFP. All addenda will be numbered consecutively, beginning with 1.

1.4 NOTIFICATION OF MOST CURRENT ADDRESS

Firms in receipt of this RFP shall notify Jamey West, Contract Specialist, Jefferson County Purchasing Department, of any address changes, contact person changes,

and/or telephone number changes no later than 48 hours prior to the date and time fixed for submission of proposals.

1.5 PROPOSAL PREPARATION COST

Cost of developing proposals is entirely the responsibility of Respondents and shall not be charged to Jefferson County.

1.6 SIGNATURE OF PROPOSAL

A transmittal letter, which shall be considered an integral part of the proposal, shall be signed by an individual who is authorized to bind the Respondent contractually. If the Respondent is a corporation, the legal name of the corporation shall be provided together with the signature of the officer or officers authorized to sign on behalf of the corporation.

If the Respondent is a partnership, the true name of the firm shall be provided with the signature of the partner or partners authorized to sign.

If the Respondent is an individual, that individual shall sign. If signature is by an agent, other than an officer of a corporation or a member of a partnership, a power of attorney or equivalent document must be submitted to the Jefferson County Purchasing Department prior to the submission of the proposal or with the proposal.

1.7 ECONOMY OF PRESENTATION

Proposals shall not contain promotional or display materials, except as they may directly answer in whole or in part questions contained in the RFP. Such exhibits shall be clearly marked with the applicable reference number of the question in the RFP. Proposals must address the technical requirements as specified in the RFP. All questions posed by the RFP must be answered concisely and clearly. Proposals that do not address each criterion may be rejected and not considered.

1.8 PROPOSAL OBLIGATION

The contents of the proposal and any clarification thereof submitted by the selected Respondent shall become part of the contractual obligation and incorporated by reference into the ensuing contract.

1.9 INCORPORATION BY REFERENCE AND PRECEDENCE

This Agreement is derived from (1) the RFP, written clarifications to the RFP and Jefferson County's response to questions; (2) the Contractor's Best and Final Offer, and (3) the Contractor's response to the RFP.

In the event of a dispute under this Agreement, applicable documents will be referred to for the purpose of clarification or for additional detail in the following order of precedence: (1) Amendments to the Agreement in reverse chronological order; (2) the Agreement, including the Scope of Work; (3) the Contractor's Best and Final Offer; (4) the RFP, including attachments thereto and written responses to questions and written clarifications; and (5) the Contractor's response to the RFP.

1.10 GOVERNING FORMS

In the event of any conflict between the terms and provisions of these requirements and the specifications, the specifications shall govern. In the event of any conflict of interpretation of any part of this overall document, Jefferson County's interpretation shall govern.

1.11 IMPLIED REQUIREMENTS

Products and services not specifically mentioned in the RFP, but which are necessary to provide the functional capabilities described by the Respondent, shall be included in the proposal.

1.12 COMPLIANCE WITH RFP SPECIFICATIONS

It is intended that this RFP describe the requirements and the response format in sufficient detail to secure comparable proposals. Failure to comply with all provisions of the RFP may result in disqualification.

1.13 EVALUATION

Jefferson County reserves the right to use all pertinent information (also learned from sources other than disclosed in the RFP process) that might affect Jefferson County's judgment as to the appropriateness of an award to the best evaluated Respondent. This information may be appended to the proposal evaluation process results. Information on a service provider from reliable sources, and not within the service provider's proposal, may also be noted and made part of the evaluation file. Jefferson County shall have sole responsibility for determining a reliable source. Jefferson County reserves the right to conduct written and/or oral discussions/interviews after the proposal opening. The purpose of such discussions/interviews is to provide clarification and/or additional information to make an award in the best interest of Jefferson County.

1.14 WITHDRAWAL OF PROPOSAL

The Respondent may withdraw its proposal by submitting a written request over the signature of an authorized individual, as described in paragraph 1.6, to the Purchasing Department any time prior to the submission deadline. The Respondent may thereafter submit a new proposal prior to the deadline. Modification or withdrawal of the proposal in any manner, oral or written, will not be considered if submitted after the deadline.

1.15 AWARD

Jefferson County reserves the right to award this contract on the basis of the **Best Offer** in accordance with the laws of Texas, to waive any formality or irregularity, to make award to more than one Respondent, and/or to reject any or all proposals. In the event the highest dollar Respondent meeting specifications is not awarded a contract, the Respondent may appear before Commissioners' Court and present evidence concerning his responsibility.

1.16 OWNERSHIP OF PROPOSAL

All proposals become the property of Jefferson County and will not be returned to Respondents.

1.17 DISQUALIFICATION OF RESPONDENT

Upon signing this proposal document, a contractor offering to sell supplies, materials, services, or equipment to Jefferson County certifies that the Respondent has not violated the antitrust laws of this state codified in Section 15.01, et seq, Business & Commerce Code, or the Federal Antitrust Laws, and has not communicated directly or indirectly the offer made to any competitor or any other person engaged in such line of business. Any or all proposals may be rejected if Jefferson County believes that collusion exists among the Respondents.

1.18 CONTRACTUAL DEVELOPMENT

The contents of the RFP and the selected proposal will become an integral part of the contract, but may be modified by provisions of the contract as negotiated. Therefore, the Respondent must be amenable to inclusion in a contract of any information provided (in writing) either in response to this RFP or subsequently during the selection process.

1.19 ASSIGNMENT

The selected vendor may not assign, sell, or otherwise transfer this contract without written permission of Jefferson County Commissioners' Court.

1.20 CONTRACT OBLIGATION

Jefferson County Commissioners' Court must award the contract, and the Jefferson County Judge or other person authorized by Jefferson County Commissioners' Court must sign the contract before it becomes binding on Jefferson County or the Respondent. **Department heads are not authorized to sign agreements for Jefferson County.** Binding agreements shall remain in effect until all products and/or services covered by this proposal have been satisfactorily delivered and accepted.

1.21 TERMINATION

Jefferson County reserves the right to terminate the contract for default if the awarded vendor breached any of the terms therein, including warranties of Respondent, or if the bidder becomes insolvent or commits acts of bankruptcy. Such right of termination is in addition to and not in lieu of any other remedies Jefferson County may have in law or equity. Default may be construed as, but not limited to, failure to deliver the proper goods and/or services within the proper amount of time, and/or to properly perform any and all other requirements to Jefferson County's satisfaction, and/or to meet all other obligations and requirements. Contracts may be terminated without cause upon thirty (30) days' written notice to either party unless otherwise specified.

1.22 INSPECTIONS

Jefferson County reserves the right to inspect any item(s) or service location(s) for compliance with specifications and requirements and needs of the using department. If a proposal cannot furnish a sample of a proposed item, where applicable, for review, or fails to satisfactorily show an ability to perform, Jefferson County can reject the Respondent as inadequate.

1.23 TESTING

Jefferson County reserves the right to test equipment, supplies, material and goods proposed for quality, compliance with specifications, and ability to meet the needs of the user. Demonstration units must be available for review. Should the goods or services fail to meet requirements and/or be unavailable for evaluation, the offer is subject to rejection.

1.24 LOSS, DAMAGE, OR CLAIM

The Respondent shall totally indemnify Jefferson County against all claims by its employees, agents, or representatives or personal injury arising from any cause. In addition, the Respondent shall totally indemnify Jefferson County against all claims of loss or damage to the Respondent's and Jefferson County's property, equipment, and/or supplies.

1.25 WAIVER OF SUBROGATION

Respondent and Respondent's insurance carrier waive any and all rights whatsoever with regard to subrogation against Jefferson County as an indirect party to any suit arising out of personal or property damages resulting from the Respondent's performance under this agreement.

1.26 CONFLICT OF INTEREST

Employees of Jefferson County are not permitted to maintain financial interest in, or receive payment, directly or indirectly, borrow from, lend to, invest in, or engage in any substantial financial transaction with any individual, organization, supplier, or subcontractor who does business with Jefferson County without disclosure.

1.27 ACKNOWLEDGMENT OF INSURANCE REQUIREMENTS

By signing its proposal, Respondent acknowledges that it has read and understands the insurance requirements for this proposal. Respondent also understands that evidence of required insurance must be submitted within fifteen (15) working days following notification of acceptance of its offer; otherwise, Jefferson County may rescind its acceptance of the Respondent's proposal. The insurance requirements are part of this package.

1.28 DELIVERY OF PROPOSALS

All proposals are to be delivered by 11:00 AM, central time, October 30, 2012 to:

Jefferson County Purchasing Department
Deborah L. Clark, Purchasing Agent
1149 Pearl Street, First Floor
Beaumont, Texas 77701

Jefferson County will not accept any proposals received after the stated time and date, and shall return such proposals unopened to the Respondent.

Jefferson County will not accept any responsibility for proposals being delivered by third party carriers.

Respondent must submit one (1) original and five (5) exact duplicate, numbered copies of the proposal (for a total of six (6)). Proposals will be opened publicly in a manner to avoid public disclosure of contents; however, only names of Respondents will be read aloud.

List the Proposal Number on the outside of the box or envelope and note "Request for Proposal enclosed."

1.29 QUESTIONS

Questions may be faxed to Jamey West, Contract Specialist at 409-835-8693 or e-mailed to jwest@co.jefferson.tx.us.

2. RESPONSE FORMAT

2.1 INTRODUCTION

Each proposal submitted in response to this RFP must be organized to correspond with those numbered sections of this RFP that require a response. Failure to arrange the proposal as requested may result in the disqualification of the proposal. Conciseness and clarity of content are emphasized and encouraged. Vague and general proposals will be considered non-responsive, and will result in disqualification. The response must be complete. Failure to provide the required information may result in the disqualification of the proposal. All pages of the proposal must be numbered and the proposal must contain an organized, paginated table of contents corresponding to the sections and pages of the proposal.

2.2 ORGANIZATION OF PROPOSAL CONTENTS

Each proposal must be organized in the manner described below.

- a. Transmittal Letter
- b. Executive Summary
- c. Table of Contents
- d. Respondent Identifying Information
- e. Respondent Personnel and Organization
- f. Project Requirements
- g. Price Proposal (Appendix A of RFP)
- i. Other information that may be helpful in the evaluation

2.3 TRANSMITTAL LETTER

The Respondent must submit a transmittal letter that identifies the entity submitting the proposal, and includes a commitment by that entity to provide the services required by Jefferson County. The transmittal letter must state that the proposal is valid for ninety (90) days from the deadline for delivery of proposals to Jefferson County. Any proposal containing a term of less than ninety (90) days for acceptance will be rejected as non-responsive.

The transmittal letter must be signed by a person legally authorized to bind the Respondent to the representations in the response. In the case of a joint proposal, each party must sign the transmittal letter. The Respondent also must indicate, in its transmittal letter, why it believes that it is the most qualified Respondent to provide the services described in this RFP.

The transmittal letter must include a statement of acceptance of the terms and conditions of the contract resulting from this RFP. If Respondent takes exception to any of the proposed terms and conditions stated in this RFP, those exceptions must be noted in the transmittal letter. However, Respondent must realize that failure to

accept the terms specified in this proposal may result in disqualification of the proposal.

The transmittal letter must include a statement of acceptance of the Standards of Performance for the contract resulting from this RFP.

2.4 EXECUTIVE SUMMARY

The Respondent must provide an executive summary of its proposal that asserts that the Respondent is providing in its response all of the requirements of this RFP. The executive summary must not exceed three (3) pages, and must represent a full and concise summary of the contents of the proposal. The executive summary must not include any information concerning the cost of the proposal. The Respondent must identify any services that are provided beyond those specifically requested. If the Respondent is providing services that do not meet the specific requirements of this RFP, but in the opinion of the Respondent are equivalent or superior to those specifically requested, any such differences must be noted in the executive summary. However, the Respondent must realize that failure to provide the services specifically required may result in disqualification of the proposal.

2.5 TABLE OF CONTENTS

Each proposal must be submitted with a table of contents that clearly identifies and denotes the location of each title and subtitle of the proposal. Additionally, the table of contents must clearly identify and denote the location of all enclosures of the proposal. The table of contents must follow the RFP's structure as much as is practical.

2.6 RESPONDENT IDENTIFYING INFORMATION

Respondents must provide the following identifying information:

- a. Name and address of business entity submitting the proposal;
- b. Type of business entity (i.e., corporation, partnership);
- c. Place of incorporation, if applicable;
- d. Name and location of major offices and other facilities that relate to the Respondent's performance under the terms of this RFP;
- e. Name, address, business and fax number of the Respondent's principal contact person regarding all contractual matters relating to this RFP;
- f. The Respondent's Federal Employer Identification Number, Jefferson County Vendor Number and Jefferson County Business License Number, if any;
- g. Full name and address for each member, partner, and employee of the Respondent (and any subcontractors) who will perform service's on this project; and
- h. A statement regarding the financial stability of the Respondent, including the ability of the Respondent to perform the functions required by this RFP and to provide those services represented by the Respondent in its response.

2.7 PROPOSED AGREEMENT

Please include a proposed agreement for ATM Installation and Operation with your response. It is Jefferson County's intention to negotiate with the Successful Respondent toward an agreement substantially similar to the Proposed Agreement.

2.8 CONFLICT OF INTEREST

Each Respondent must disclose any existing or potential conflict of interest relative to the performance of the requirements of this RFP. Examples of potential conflicts may include an existing business or personal relationship between the Respondent, its principal, or any affiliate or subcontractor, with Jefferson County or any other entity or person involved in any way in the project that is the subject of this RFP. Similarly, any personal or business relationship between the Respondent, the principals, or any affiliate or subcontractor, with any employee of Jefferson County or its suppliers must be disclosed. Any such relationship that might be perceived or represented as a conflict must be disclosed. Failure to disclose any such relationship or reveal personal relationships with state employees may be cause for contract termination. Jefferson County will decide if an actual or perceived conflict should result in proposal disqualification.

Each Respondent must reveal any past or existing relationship between the Respondent, its principal, employees, or any affiliate or subcontractor, with any Jefferson County agency, entity, Jefferson County employee, or other person in anyway involved in Jefferson County's procurement and/or contracting processes. It shall be the sole prerogative of Jefferson County to determine if such relationship constitutes a conflict of interest.

By submitting a proposal in response to this RFP, all Respondents affirm that they have not given, nor intend to give, at any time hereafter any economic opportunity, future employment, gift, loan, gratuity, special discount, trip, favor, or service to a public servant or any employee or representative of same, in connection with this procurement.

**FAILURE BY RESPONDENT TO INCLUDE ALL LISTED ITEMS
MAY RESULT IN THE REJECTION OF PROPOSAL.**

3. PROPOSAL SUBMITTAL

The Proposal is due no later than 11:00 AM, October 30, 2012, and shall include the following:

- Cover sheet identifying the contract/project being proposed, the name and address of Respondent, the date of the proposal, and the telephone and facsimile numbers of Respondent.
- An acknowledgment and/or response to each section of the proposal.
- Form of business (e.g., corporation, sole proprietorship, partnership); if corporation the date and state of incorporation.
- Identification of three (3) entities for which the Respondent is providing or has provided automated teller machines, including the name, position, and telephone number of a contact person at each entity.
- Identification of all legal claims, demands, contracts terminated or lawsuits filed, threatened, or pending against the Respondent and/or its principal/officers for the last three (3) years, as well as identification of any administrative actions or warnings taken or issued by any federal, state, or local governmental agency to Respondent and/or its principals/officers with regard to the provision of the same or similar service as covered by this RFP, or the payment of moneys under the terms of any agreement(s) relating to such services.
- Same contract with compensation sections blank.
- One (1) original and five (5) copies of the proposal should be mailed or delivered to:

Jefferson County Courthouse
Purchasing Department (First Floor)
1149 Pearl Street
Beaumont, TX 77701

- Explanations, exceptions, comments, etc., pertaining to the specific sections of the specifications. All comments shall be listed and numbered in order of the respective article of the specification.

4. SCOPE OF SERVICES

4.1 BACKGROUND

Jefferson County, Texas (“Jefferson County”) operates numerous buildings in the County, some of which are involved in the collection of taxes and fees for various purposes. At these locations, the convenience of automated teller machines (ATMs) at is beneficial to the County, the public, and the employees.

4.1.1 Surcharge Rate – There is currently a \$1.50 charge per transaction, \$0.75 of which is paid quarterly to Jefferson County.

4.1.2 Transaction History – A transaction history is as follows. A breakdown by location is not available.

Date	Number of Transactions
December 2008	1,001
March 2009	1,084
June 2009	1,089
September 2009	991
December 2009	893
March 2010	1,555
June 2010	1,630
September 2010	1,113
December 2010	1,244
March 2011	1,931
June 2011	2,074
September 2011	2,236
December 2011	1,060
March 2012	1,284

4.2 CURRENT AND POSSIBLE LOCATIONS FOR ATMS

The following table shows current and possible additional locations for ATMs, as well of description of the use and traffic of each location.

	Locations	Description	Contact
1	Historic Courthouse 1149 Pearl Street New Courthouse 1001 Pearl Street Beaumont	The two courthouses (which are connected) are used by over 500 County employees, as well as by members of the public. The buildings include courts, justice of the peace offices, tax offices, and a café. There is currently an ATM in the first floor hallway connecting the two buildings.	Harry Fuselier 409-835-8511
2	Annex I 215 Franklin St. Beaumont	Adjacent to the courthouses, this building is used by about 40 County employees, as well as by members of the public. The building includes court rooms and a justice of the peace office. The building does not currently have an ATM.	Harry Fuselier 409-835-8511

	Locations	Description	Contact
3	Annex II 820 Neches St. Beaumont	This building contains the Adult Probation Department, and is used by over 50 County employees and numerous members of the public. The building does not currently have an ATM.	Harry Fuselier 409-835-8511
4	Mid County Tax Office 4605 Jerry Ware Dr. Beaumont	This building is used by approximately 11 County employees, as well as by members of the public. The building does not currently have an ATM.	Frank Adams 409-727-2173
5	Subcourthouse 525 Lakeshore Dr. Pt. Arthur	This building is used by approximately 50 County employees, as well as by members of the public. The building includes courts, justice of the peace offices, and a tax office. There is currently an ATM at this location.	Mark Bernard 409-983-8307
6	Jack Brooks Regional Airport – Main Terminal	The airport has two gates, which served approximately 36,000 passengers in 2010. There are approximately 13 employees working at the airport. There is currently an ATM at this location.	Alex Rupp

	Location: Ford Park	Description	Contact
7	Ford Park Arena, Amphitheater, Fairgrounds, Ball Fields, Exhibit Hall 5115 1H10 South, Beaumont	<p>There are approximately 10-12 employees at Ford Park. The number of visitors varies considerably with the schedule of events at these venues. There are currently ATMs at the Arena and Amphitheater. However, additional ATMs (to be included in this bid) are to be installed and operated at: Ford Park Ball Fields (1 machine), Exhibit Hall (1 machine), and inside Ford Arena on the concourse (1 machine).</p> <p>Portable ATMs: Portable ATMs (1-2) machines are to be accessible for events at the Ford Park Pavilion or Barn/Midway.</p> <p>All ATMs at Ford Park: Must have 24/7 tech support; with the ability to dispatch a local tech for service or refill on weekends and holiday.</p>	John Hughes 409-951-5400

The successful Contractor will have the option of investigating the feasibility of placing ATMs in other County buildings.

4.3 SECURITY REQUIREMENTS

ATMs provided shall include up-to-date security features to discourage misuse of the machines.

4.4 INSTALLATION REQUIREMENTS

The successful vendor shall install ATMs within 30 days of award. The vendor shall coordinate installation with the designated point of contact at each location.

4.5 SERVICE REQUIREMENTS

Respondents shall provide plans for service requirements, including service call response time, frequency of maintenance, etc.

4.6 ADA REQUIREMENTS

Proposals shall include information showing that respondents' machines comply with requirements of the Americans with Disabilities Act (ADA), including Section 308.2 of the 2010 ADA Standards for Accessible Design, as follows:

§308.2 Forward Reach.

§308.2.1 Unobstructed. Where a forward reach is unobstructed, the high forward reach shall be 48 inches (1220 mm) maximum and the low forward reach shall be 15 inches (380 mm) minimum above the finish floor or ground.

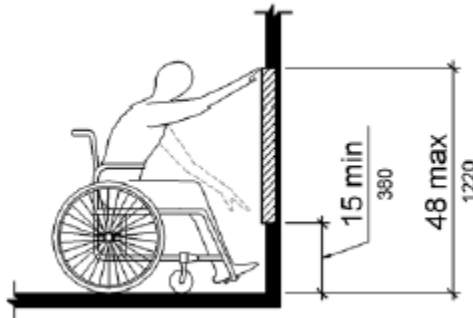

Figure 308.2.1 Unobstructed Forward Reach

§308.2.2 Obstructed High Reach. Where a high forward reach is over an obstruction, the clear floor space shall extend beneath the element for a distance not less than the required reach depth over the obstruction. The high forward reach shall be 48 inches (1220 mm) maximum where the reach depth is 20 inches (510 mm) maximum. Where the reach depth exceeds 20 inches (510 mm), the high forward reach shall be 44 inches (1120 mm) maximum and the reach depth shall be 25 inches (635 mm) maximum.

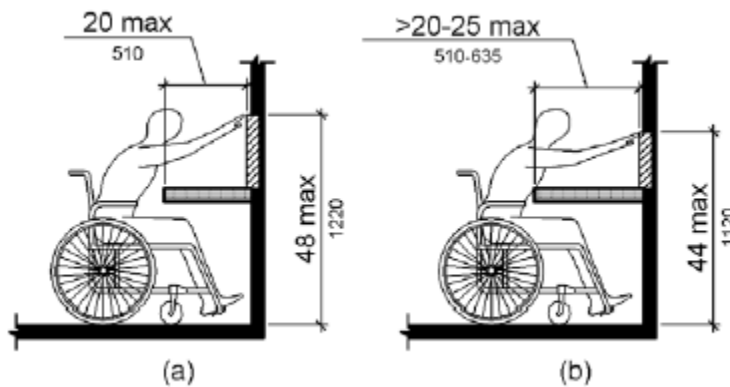

Figure 308.2.2 Obstructed High Forward Reach

308.3 Side Reach.

§308.3.1 Unobstructed. Where a clear floor or ground space allows a parallel approach to an element and the side reach is unobstructed, the high side reach shall be 48 inches (1220 mm) maximum and the low side reach shall be 15 inches (380 mm) minimum above the finish floor or ground.

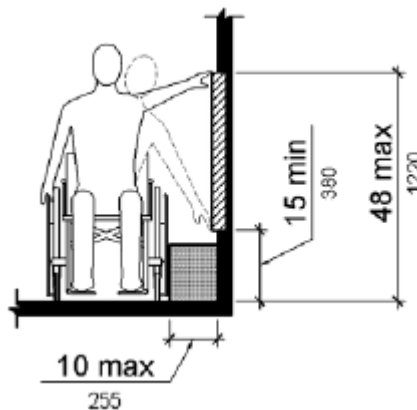

Figure 308.3.1 Unobstructed Side Reach

§308.3.2 Obstructed High Reach. Where a clear floor or ground space allows a parallel approach to an element and the high side reach is over an obstruction, the height of the obstruction shall be 34 inches (865 mm) maximum and the depth of the obstruction shall be 24 inches (610 mm) maximum. The high side reach shall be 48 inches (1220 mm) maximum for a reach depth of 10 inches (255 mm) maximum. Where the reach depth exceeds 10 inches (255 mm), the high side reach shall be 46 inches (1170 mm) maximum for a reach depth of 24 inches (610 mm) maximum.

4.7 DEFINITIONS

4.7.1 “Addenda” – Means any written or graphic instruments issued by Jefferson County prior to the consideration of Proposals which modify or interpret the Proposal Documents by additions, deletions, clarifications, or corrections.

4.7.2 “Agreement” – Is that agreement which is actually executed by Jefferson County and the Successful Respondent.

4.7.3 “Incidental Interests” – Shall include all contractual rights involving the Jail to which Jefferson County is a party, if any, including, without limitation, all leases, licenses, easements and permits affecting the Jail.

4.7.4 “Notice” – Is that Legal Notice which refers to the Agreement and this RFP and which was printed in the Beaumont Enterprise and The Port Arthur News on November 17 and November 24, 2010, newspapers of general circulation in Jefferson County, Texas on at least two separate dates. A copy of the Notice is attached as the cover page for the RFP package.

4.7.5 “Proposal Documents” – The Legal Notice, RFP including attachments, and any Addenda issued by Jefferson County prior to the consideration of any Proposals.

4.7.6 “Proposal Form” – The form attached to this RFP package as Appendix A.

4.7.7 “Proposal” – Is a complete, properly signed response submitted in accordance with this RFP which is irrevocable during the specified period for evaluation and acceptance of Proposals, and, once an RFP is accepted by Jefferson County, it constitutes agreement by the Successful Respondent to execute a contract document in substantially the same form as the Proposed Agreement, with any revisions or modifications expressly agreed upon by the Successful Respondent and Jefferson County.

4.7.8 “Respondent” – A person or entity who submits a proposal in response to this RFP.

4.7.9 “RFP” – Refers to this document, together with the attachments thereto, and Notice.

4.7.10 “Successful Respondent” – The responsible Respondent who, in Jefferson County’s sole opinion, submits the Proposal which is in the best interest of Jefferson County, taking into account factors including but not limited to cost, experience, and competency of Respondent, and to whom Jefferson County intends to award the Agreement.

5. PROJECT REQUIREMENTS

5.1 RESPONDENT EXPERIENCE

The successful Respondent must demonstrate extensive experience in and understanding required in order to carry out the intent of this project. Further, Respondent must possess a background of at least (5) five years experience in ATM (Automated Teller Machine) ownership, installation, and operation services.

The Respondent must describe in detail the current and historical experience the Respondent and its subcontractors have that would be relevant to completing the project. References must contain the name of key contacts and a telephone number.

The Respondent must briefly state why it believes its proposed services best meet Jefferson County's needs and RFP requirements, and the Respondent also must concisely describe any additional features, aspects, or advantages of its services in any relevant area not covered elsewhere in its proposal.

6. PROPOSAL EVALUATION AND SELECTION PROCESS

6.1 INTRODUCTION

The proposal evaluation and selection process is detailed in this section, as are other factors, and the format in which the cost response of each proposal must be submitted.

6.2 PRICE PROPOSAL

The Respondent must utilize the form provided in Appendix A in its submission of a cost proposal in response to this RFP. The cost proposal must be included in each copy of the proposal. Any reworked version of Appendix A that is intended to be a substitute for Appendix A, that is provided by a Respondent may be determined as non-responsive, and may result in the proposal's disqualification.

6.3 PROPOSAL EVALUATION AND SELECTION

Prior to the receipt of proposals, Jefferson County will establish an Evaluation Committee. The Committee is expected to include representatives from Jefferson County Auditor's Department, Purchasing Department, Legal Department, and Human Resources

6.4 EVALUATION CRITERIA

- a. **Cost (50 points).** The proposal shall fully detail and identify all revenue to be received by the County.
- b. **Qualifications/Experience (30 points).** The proposal shall fully detail the Offeror's qualifications and past experience at operating a facility of this type. (Include references)
- c. **Adherence to Security Features (10 points).** The proposal shall list at least three (3) references from current clients.
- d. **Adherence to ADA Standards (10 points).**

The Evaluation Committee may elect to require an oral presentation from each qualified Respondent of the information contained in their proposal. Any invitation for an oral presentation will be solely for the purpose of clarifying proposals received from each qualifying Respondent, and will not represent any decision on the part of the evaluation committee as to the selection of a successful Respondent.

Upon completion of their review and any oral presentations, the Evaluation Committee will convene one or more times to discuss the proposals as a group. Each Evaluation Committee member will individually score each proposal. The Jefferson County Purchasing Department will collect all scores and aggregate the scores of all Committee members. The Purchasing Department will then identify the proposal that scored the highest in the selection process according to the evaluation criteria described in this RFP and make a recommendation to the Commissioners' Court.

APPENDIX A. PAYMENT PROPOSAL

The undersigned bidder, having become familiar with this Invitation for Bids agrees to furnish Automated Teller Machines at various locations within Jefferson County ON AN AS-NEEDED BASIS in accordance with the Agreement.

1. The Bidder will charge a transaction fee of \$_____ per transaction. This amount will not include any additional fees charged by customers' financial institution.
2. Estimated number of persons who, because they have an account with bidder, will pay no transaction fee to bidder: _____
3. Amount to be paid to Jefferson County for each transaction on a quarterly basis: \$_____.

The undersigned hereby certifies that he or she has read the terms of this RFP and understands that Jefferson County reserves the right to waive any informality in or to reject any or all bids.

Company: _____

Address: _____

Telephone: _____ Fax: _____

Contact Name (please print): _____

Authorized Signature: _____

State of Incorporation or Primary Place of Business:

Company Name:	
Authorized Signature:	
Title:	

RESPONDENT MUST RETURN THIS PAGE WITH OFFER

APPENDIX B. VENDOR REFERENCES

Please list at least three (3) companies or governmental agencies where the same or similar products and/or services as contained in this specification package were recently provided.

THIS FORM MUST BE RETURNED WITH YOUR BID.

REFERENCE ONE

Government/Company Name: _____

Address: _____

Contact Person and Title: _____

Phone: _____ Fax: _____

Contract Period: _____ Scope of Work: _____

REFERENCE TWO

Government/Company Name: _____

Address: _____

Contact Person and Title: _____

Phone: _____ Fax: _____

Contract Period: _____ Scope of Work: _____

REFERENCE THREE

Government/Company Name: _____

Address: _____

Contact Person and Title: _____

Phone: _____ Fax: _____

Contract Period: _____ Scope of Work: _____

RESPONDENT MUST RETURN THIS PAGE WITH OFFER

APPENDIX C. SIGNATURE PAGE

As permitted under Article 4413 (32c) V.A.C.S., other governmental entities may wish to participate under the same terms and conditions contained in this contract (i.e., piggyback). In the event any other entity participates, all purchase orders will be issued directly from and shipped directly to the entity requiring supplies/services. Jefferson County shall not be held responsible for any orders placed, deliveries made or payment for supplies/services ordered by another entity. Each entity reserves the right to determine their participation in this contract.

Would bidder be willing to allow other governmental entities to piggyback off this contract, if awarded, under the same terms and conditions?..... **Yes** **No**

This bid shall remain in effect for ninety (90) days from bid opening and shall be exclusive of federal excise and state and local sales tax (exempt).

The undersigned agrees, if this bid is accepted, to furnish any and all items upon which prices are offered, at the price and upon the terms and conditions contained in the Invitation for Bid, Conditions of Bidding, Terms of Contract, and Specifications and all other items made a part of the accepted contract.

The undersigned affirms that they are duly authorized to execute the contract, that this company, corporation, firm, partnership or individual has not prepared this bid in collusion with any other bidder, and that the contents of this bid as to prices, terms or conditions of said bid have not been communicated by the undersigned nor by any employee or agent to any other bidder or to any other person(s) engaged in this type of business prior to the official opening of this bid. And further, that neither the bidder nor their employees nor agents have been for the past six (6) months directly nor indirectly concerned in any pool or agreement or combination to control the price of goods or services on, nor to influence any person to bid or not to bid thereon.

Bidder (Entity Name)	Signature
Street & Mailing Address	Print Name
City, State & Zip	Date Signed
Telephone Number	Fax Number
E-mail Address	

RESPONDENT MUST RETURN THIS PAGE WITH OFFER

APPENDIX D. CONFLICT OF INTEREST QUESTIONNAIRE

For vendor or other person doing business with local government entity	
<p>This questionnaire is being filed in accordance with chapter 176 of the Local Government Code by a person doing business with the governmental entity.</p> <p>By law this questionnaire must be filed with the records administrator of the local government not later than the 7th business day after the date the person becomes aware of facts that require the statement to be filed. See Section 176.006 Local Government Code.</p> <p>A person commits an offense if the person violates Section 176.0006, Local Government Code. An offense under this section is a Class C misdemeanor.</p>	OFFICE USE ONLY
1. Name of person doing business with local governmental entity.	
<p>2. <input type="checkbox"/> Check this box if you are filing an update to a previously filed questionnaire.</p> <p style="padding-left: 40px;">(The law requires that you file an updated completed questionnaire with the appropriate filing authority not later than September 1 of the year for which an activity described in Section 176.006(a), Local Government Code, is pending and not later than the 7th business day after the date the originally filed questionnaire becomes incomplete or inaccurate.)</p>	
3. Describe each affiliation or business relationship with an employee or contractor of the local government entity who makes recommendations to a local government officer of the local governmental entity with respect to expenditure of money.	
4. Describe each affiliation or business relationship with a person who is a local government officer and who appoints or employs a local government officer of the local governmental entity that is the subject of this questionnaire.	

RESPONDENT MUST RETURN THIS PAGE WITH OFFER

CONFLICT OF INTEREST QUESTIONNAIRE

FORM CIQ
Page 2

For vendor or other person doing business with local government entity

5. Name of local government officer with whom filer has affiliation or business relationship. (Complete this section only if the answer to A, B, or C is YES.)

This section, item 5 including subparts A, B, C & D, must be completed for each officer with whom the filer has affiliation or business relationship. Attach additional pages to this Form CIQ as necessary.

A. Is the local government officer named in this section receiving or likely to receive taxable income from the filer of the questionnaire?

Yes No

B. Is the filer of the questionnaire receive or likely to receive taxable income from or at the direction of the local government officer named in this section AND the taxable income is not from the local government entity?

Yes No

C. Is the filer of the questionnaire affiliated with a corporation or other business entity that the local government officer serves as an officer or director, or holds an ownership of 10 percent or more?

Yes No

D. Describe each affiliation or business relationship:

6. Describe any other affiliation or business relationship that might cause a conflict of interest.

7.

Signature of person doing business with the governmental entity

Date

RESPONDENT MUST RETURN THIS PAGE WITH OFFER

APPENDIX E. GOOD FAITH EFFORT (GFE)

DETERMINATION CHECKLIST

This information must be submitted with your bid.

Instructions: In order to determine if a “Good Faith Effort” was made in soliciting HUBs for subcontracting opportunities, the following checklist and supporting documentation shall be completed by the Prime Contractor/Consultant, and returned with the Prime Contractor/Consultant’s bid. This list contains the **minimum** efforts that should be put forth by the Prime Contractor/Consultant when attempting to achieve or exceed the goals of HUB Subcontractor participation. The Prime Contractor/Consultant may extend his/her efforts in soliciting HUB Subcontractor participation beyond what is listed below.

Did the Prime Contractor/Consultant . . .

- Yes No 1. To the extent practical, and consistent with standard and prudent industry standards, divide the contract work into the smallest feasible portions, to allow for maximum HUB Subcontractor participation?
- Yes No 2. **Notify** in writing a reasonable number of HUBs, allowing sufficient time for effective participation of the planned work to be subcontracted?
- Yes No 3. **Provide** HUBs that were genuinely interested in bidding on a subcontractor, adequate information regarding the project (i.e., plans, specifications, scope of work, bonding and insurance requirements, and a point of contact within the Prime Contractor/Consultant’s organization)?
- Yes No 4. **Negotiate** in good faith with interested HUBs, and not reject bids from HUBs that qualify as lowest and responsive bidders?
- Yes No 5. **Document** reasons HUBs were rejected? Was a written rejection notice, including the reason for rejection, provided to the rejected HUBs?
- Yes No 6. If Prime Contractor/Consultant has zero (0) HUB participation, **please explain the reasons why.**

If “No” was selected, please explain and include any pertinent documentation with your bid. If necessary, please use a separate sheet to answer the above questions.

Printed Name of Authorized Representative

Signature

Title

Date

RESPONDENT MUST RETURN THIS PAGE WITH OFFER

APPENDIX F. NOTICE OF INTENT (NOI)

To SUBCONTRACT WITH HISTORICALLY UNDERUTILIZED BUSINESS (HUB)

This information must be submitted with your bid.

Instructions for Prime Contractor/Consultant: Please submit the form to the Purchasing Agent's Representative after contract award, but prior to beginning performance on the contract. Please submit one form for each HUB Subcontractor/Subconsultant with proper signatures, per the terms and conditions of your contract.

Contractor Name: _____ HUB: p Yes p No

Address: _____
Street City State Zip

Phone (with area code): _____ Fax (with area code): _____

Project Title & No.: _____

Prime Contract Amount: \$ _____

HUB Subcontractor Name: _____

HUB Status (Gender & Ethnicity): _____

Certifying Agency: Tx. Bldg & Procurement Comm. Jefferson County Tx Unified Certification Prog.

Address: _____
Street City State Zip

Phone (with area code): _____ Fax (with area code): _____

Proposed Subcontract Amount: \$ _____ Percentage of Prime Contract: _____ %

Description of Subcontract Work to be Performed: _____

Printed Name of Contractor Representative Signature of Representative Date

Printed Name of HUB Signature of Representative Date

Note: Nothing on this Notice of Intent Form is intended to confer any rights, expressed or implied, to any third parties.

Pre-Approval for Subcontractor Substitutions must be obtained from the Jefferson County Purchasing Agent's Representative. The "HUB Subcontractor/Subconsultant Change Form" must be completed and faxed to 409-835-8456.

RESPONDENT MUST RETURN THIS PAGE WITH OFFER

APPENDIX G. HISTORICAL UNDERUTILIZED BUSINESS (HUB)

SUBCONTRACTING PARTICIPATION DECLARATION FORM

PAGE 1 OF 4

This information must be submitted with your bid.

Prime Contractor: _____ HUB: Yes No

HUB Status (Gender & Ethnicity): _____

Address: _____
Street City State Zip

Phone (with area code): _____ Fax (with area code): _____

Project Title & No.: _____ IFB/RFP No.: _____

Total Contract: \$ _____ Total HUB Subcontract(s): \$ _____

Construction HUB Goals: 12.8% MBE:: _____ % 12.6% WBE: _____ %

Sub-goals: 1.7 African-American, 9.7% Hispanic, 0.7% Native American, 0.8% Asian American.
Use these goals as a guide to diversify.

FOR HUB OFFICE USE ONLY:

Verification date HUB Program Office reviewed and verified HUB Sub information Date: _____ Initials: _____

PART I. HUB SUBCONTRACTOR DISCLOSURE

HUB Subcontractor Name: _____

HUB Status (Gender & Ethnicity): _____

Certifying Agency: Texas Bldg & Procurement Comm. Texas Unified Certification Prog.

Address: _____
Street City State Zip

Contact person: _____ Title: _____

Phone (with area code): _____ Fax (with area code): _____

Proposed Subcontract Amount: \$ _____ Percentage of Prime Contract: _____ %

Description of Subcontract Work to be Performed: _____

RESPONDENT MUST RETURN THIS PAGE WITH OFFER

**HISTORICALLY UNDERUTILIZED BUSINESS (HUB)
SUBCONTRACTING PARTICIPATION DECLARATION FORM
PAGE 2 OF 4**

HUB SUBCONTRACTOR DISCLOSURE

PART I: Continuation Sheet

(Duplicate as Needed)

HUB Subcontractor Name: _____

HUB Status (Gender & Ethnicity): _____

Certifying Agency: Tx. Bldg & Procurement Comm. Jefferson County Tx Unified Certification Prog.

Address: _____
 Street City State Zip

Contact person: _____ Title: _____

Phone (with area code): _____ Fax (with area code): _____

Proposed Subcontract Amount: \$ _____ Percentage of Prime Contract: _____ %

Description of Subcontract Work to be Performed: _____

HUB Subcontractor Name: _____

HUB Status (Gender & Ethnicity): _____

Certifying Agency: Tx. Bldg & Procurement Comm. Jefferson County Tx Unified Certification Prog.

Address: _____
 Street City State Zip

Contact person: _____ Title: _____

Phone (with area code): _____ Fax (with area code): _____

Proposed Subcontract Amount: \$ _____ Percentage of Prime Contract: _____ %

Description of Subcontract Work to be Performed: _____

**All HUB Subcontractor Participation may be verified with the
HUB Subcontractor(s) listed on Part I.**

RESPONDENT MUST RETURN THIS PAGE WITH OFFER

**HISTORICALLY UNDERUTILIZED BUSINESS (HUB)
SUBCONTRACTING PARTICIPATION DECLARATION FORM**

PAGE 3 OF 4

PART II: STATEMENT OF NON-COMPLIANCE FOR NOT MEETING HUB SUBCONTRACTING GOALS

Please complete Good Faith Effort (GFE) Checklist and attach any supporting documentation.

Our firm was unable to meet the HUB goals for this project for the following reasons:

- All subcontractors to be utilized are "Non-HUBs." (Complete Part III)
- HUBs were solicited but did not respond.
- HUBs solicited were not competitive.
- HUBs were unavailable for the following trade(s):
- Other: _____

Was the Jefferson County HUB Office contacted for assistance in locating HUBs? Yes No

PART III: DISCLOSURE OF OTHER "NON-HUB" SUBCONTRACTS

The bidder shall use this area to provide a listing of all "Non-HUB" Subcontractors, including suppliers that will perform under this project. A list of those "Non-HUB" Subcontractors the bidder selects, after bid submission, shall be provided to the Purchasing Office not later than five (5) calendar days after being notified that bidder is the apparent low bidder. A list of those "Non-HUB" Subcontractors that are selected after contract award must be provided **immediately** after their selection.

Subcontractor Name: _____

Address: _____
Street City State Zip

Contact person: _____ Title: _____

Phone (with area code): _____ Fax (with area code): _____

Proposed Subcontract Amount: \$ _____ Percentage of Prime Contract: _____ %

Description of Subcontract Work to be Performed: _____

Subcontractor Name: _____

Address: _____
Street City State Zip

Contact person: _____ Title: _____

Phone (with area code): _____ Fax (with area code): _____

Proposed Subcontract Amount: \$ _____ Percentage of Prime Contract: _____ %

Description of Subcontract Work to be Performed: _____

RESPONDENT MUST RETURN THIS PAGE WITH OFFER

**HISTORICALLY UNDERUTILIZED BUSINESS (HUB)
SUBCONTRACTING PARTICIPATION DECLARATION FORM**
PAGE 4 OF 4

Subcontractor Name: _____

Address: _____
Street City State Zip

Contact person: _____ Title: _____

Phone (with area code): _____ Fax (with area code): _____

Proposed Subcontract Amount: \$ _____ Percentage of Prime Contract: _____ %

Description of Subcontract Work to be Performed: _____

Subcontractor Name: _____

Address: _____
Street City State Zip

Contact person: _____ Title: _____

Phone (with area code): _____ Fax (with area code): _____

Proposed Subcontract Amount: \$ _____ Percentage of Prime Contract: _____ %

Description of Subcontract Work to be Performed: _____

I hereby certify that I have read the *HUB Program Instructions and Information*, truthfully completed all applicable parts of this form, and **attached any necessary support documentation as required**. I fully understand that intentionally falsifying information on this document may result in my not receiving a contract award or termination of any resulting contract.

Name (print or type): _____

Title: _____

Signature: _____

Date: _____

E-mail address: _____

Contact person that will be in charge of invoicing for this project:

Name (print or type): _____

Title: _____

Date: _____

E-mail address: _____

RESPONDENT MUST RETURN THIS PAGE WITH OFFER

APPENDIX H. RESIDENCE CERTIFICATION/TAX FORM

Pursuant to Texas Government Code §2252.001 *et seq.*, as amended, Jefferson County requests Resident Certification. §2252.001 *et seq.* of the Government Code provides some restrictions on the awarding of governmental contracts; pertinent provisions of §2252.001 are stated below:

- (3) "Nonresident bidder" refers to a person who is not a resident.
- (4) "Resident bidder" refers to a person whose principal place of business is in this state, including a contractor whose ultimate parent company or majority owner has its principal place of business in this state.

- I certify that _____ [company name] is a Resident Bidder of Texas as defined in Government Code §2252.001.
- I certify that _____ [company name] is a Nonresident Bidder as defined in Government Code §2252.001 and our principal place of business is _____ (city and state).

Taxpayer Identification Number (T.I.N.):	
Company Name submitting bid/proposal:	
Mailing address:	
If you are an individual, list the names and addresses of any partnership of which you are a general partner:	

Property: List all taxable property owned by you or above partnerships in Jefferson County.

Jefferson County Tax Acct. No.*	Property address or location**

* This is the property amount identification number assigned by the Jefferson County Appraisal District.

** For real property, specify the property address or legal description. For business property, specify the address where the property is located. For example, office equipment will normally be at your office, but inventory may be stored as a warehouse or other location.

Do you carry Health Insurance on your employees? Yes No

If yes, what is the percentage of employees insured? _____%

RESPONDENT MUST RETURN THIS PAGE WITH OFFER

APPENDIX I. BID AFFIDAVIT

The undersigned certifies that the bid prices contained in this bid have been carefully reviewed and are submitted as correct and final. Bidder further certifies and agrees to furnish any and/or all commodities upon which prices are extended at the price offered, and upon the conditions contained in the specifications and the Notice to Bidders.

STATE OF _____ COUNTY OF _____

BEFORE ME, the undersigned authority, a Notary Public in and for the State of _____,

on this day personally appeared _____, who
(name)

after being by me duly sworn, did depose and say:

"I, _____ am a duly authorized officer of/agent
(name)

for _____ and have been duly authorized to execute the
(name of firm)

foregoing on behalf of the said _____.
(name of firm)

I hereby certify that the foregoing bid has not been prepared in collusion with any other bidder or other person or persons engaged in the same line of business prior to the official opening of this bid. Further, I certify that the bidder is not now, nor has been for the past six (6) months, directly or indirectly concerned in any pool or agreement or combination, to control the price of services/commodities bid on, or to influence any person or persons to bid or not to bid thereon."

Name and address of bidder: _____

Fax: _____ Telephone# _____

by: _____ Title: _____
(print name)

Signature: _____

SUBSCRIBED AND SWORN to before me by the above-named _____ on

this the _____ day of _____, 2012.

Notary Public in and for
the State of _____

Bidder Shall Return Completed Form with Offer.