



ADDENDUM NO. 1

Addendum Issued Date: April 24, 2013

Cheek Community Sewer Improvements – Cheek Phase III

Jefferson County, Texas

Bid No.: IFB 13-006/KJS

TXCDBG NO. 711281

d.p. Job No. 112-29B

The following information is offered for clarification or modification to the project information you now hold.

1. CONTRACT DOCUMENT

(a) Revise **Legal Notice First Paragraph, Second Line** to read as follows:

“All bids must be submitted with an original and three (3) copies to the Jefferson County Purchasing Agent, 1149 Pearl Street, 1st Floor, Beaumont, Texas 77701, no later than **11:00 AM, Tuesday, May 7, 2013.**”

(b) Revise **Legal Notice Fifth Paragraph** to read as follows:

BID NAME: Cheek Community Sewer Improvements – Cheek Phase III
BID NO: IFB 13-006/KJS
DUE DATE/TIME: 11:00 am, May 7, 2013
MAIL OR DELIVER TO: Jefferson County Purchasing Department
1149 Pearl Street, 1st Floor
Beaumont, TX 77701

(c) Replace **Notice to Bidders Page 1** with revised **Notice to Bidders Page 1** attached.

Clarification: Bid Date has been delayed one week to **May 7, 2013.**

(d) Revise **Standard Form of Agreement Page 16, Second Paragraph bullet list** to read as follows:

- **Install approximately 7,520 L.F. of 4” and approximately 115 L.F. of 3” PVC SDR-26 Low Pressure Sanitary Sewer Force Mains.**
- **Install Eleven (11) grinder pump units.**

(e) Revise **Summary of Work §1. Installation of Low Pressure Sewer Force Main, First Paragraph, First Sentence** to read as follows:

“Install approximately **7,520 L.F. of 4” (6”, if alternate bid is accepted), 300 L.F. 6” HDPE Directionally Drilled and approximately 115 L.F. of 3” PVC SDR-26 Class 160 Sewer Force Mains including “Mega-Lug” joint restraints for all valves and fittings.**”

(f) Revise **Summary of Work §2 Installation of Simplex Grinder Pump Units, First Line** to read as follows:

“Furnish and install **Eleven (11)** fully operational Grinder Pump Units per plans and”.....



d.p. Consulting Engineers, Inc.

3727 Doctors Drive
Port Arthur, TX 77642
Phone: 409-983-6263
Fax : 409-983-6265
Firm Registration: F-3356
Email : dp@dpengineersinc.com

(g) Revise **Summary of Work §3 Service Lines, First Sentence to read as follows:**

“Short side services consist of installing the 1 ¼” Polyethylene pipe, shut off valve, check valve and valve box at the property line per Plan Details (**See Sheet 11 of 13**).”

2. BID PROPOSAL

- (a) Replace **Bid Proposal Pages 84 to 87** with revised **Bid Proposal Pages 84 to 87** attached.
- (b) Replace **Alternate Bid Proposal Pages 88 to 91** with revised **Alternate Bid Proposal Pages 88 to 91** attached.
- (c) Replace **Supplemental Items Proposal Page 92** with revised **Supplemental Items Proposal Page 92 and 92A** attached.

Clarification: Quantities for several Bid Items have been revised and one additional bid item is added to the Bid Proposal and Alternate Bid Proposal, for service lines by linear foot. Additional Supplemental Items are added to allow for installation of 2” force main if the County elects on extended services.

3. CONSTRUCTION PLANS

- (a) Replace **Plans Sheets 9 and 12** with revised **Plan Sheets 9 and 12** attached.
- (b) **Plan Sheet 9A**, attached, has been added to the Construction Plans to show profile details of “Bore & Casing” under the County Roads.

Clarification: Plan Sheet-9 includes additional force mains along Boyt Road. A pipe bedding detail for mainline force main is added to the Plan Sheet 12.

4. LIST OF ADDRESSES FOR GRINDER UNIT INSTALLATIONS

Residents receiving new grinder units are listed in the attachment.

5. WAGE RATE DECISION

The most recent Wage Rate General Decision Number TX130079 04/05/2013 TX79, attached, has been added to the bid document.

- 6. Temporary easements will be procured from the property owners receiving service lines and grinder units allowing the General Contractor right of access onto private property to install the said improvements.

Received

Date: _____

Acknowledged: _____

The changes listed above will be considered part of the Bid Package. Bidders are advised that each Addendum issued must be recognized by signature and a copy of all addenda must be submitted with Bid.

Notice to Bidders

IFB 13-006/KJS

SEALED BIDS, IN TRIPPLICATE, SHALL BE SUBMITTED TO:

**JEFFERSON COUNTY PURCHASING DEPARTMENT, FIRST FLOOR
JEFFERSON COUNTY COURTHOUSE
1149 PEARL STREET, BEAUMONT, TEXAS 77701**

**NO LATER THAN 11:00 AM, CENTRAL TIME, TUESDAY,
MAY 7, 2013**

**MARK ENVELOPE:
"IFB 13-006/KJS- SEALED BID"**

JEFFERSON COUNTY WILL NOT BE RESPONSIBLE
FOR UNMARKED OR IMPROPERLY MARKED ENVELOPES.

There is no expressed or implied obligation for Jefferson County to reimburse responding bidders for any expense incurred in preparing bid in response to this request and Jefferson County will not reimburse bidders for these expenses.

All bids must be received in the Purchasing Department before opening at **11:00AM CST on May 7, 2013**. Bids received after the date and time above will be considered void and unacceptable and returned to the vendor unopened. Jefferson County is not responsible for lateness or non-delivery of mail, carrier, etc., and the date/time stamp in the Purchasing Office shall be the official time of receipt.

PLEASE TAKE NOTE OF THE FOLLOWING COUNTY HOLIDAYS:

| | |
|-------------------|------------------------|
| January 1, 2013 | September 2, 2013 |
| January 21, 2013 | November 11, 2013 |
| February 18, 2013 | November 28 & 29, 2013 |
| March 29, 2013 | December 25& 26, 2013 |
| May 27, 2013 | January 1, 2014 |
| July 4, 2013 | |

FACSIMILE TRANSMITTALS SHALL NOT BE ACCEPTED.

The enclosed Notice to Bidders and accompanying Specifications and Bid Forms must be completed prior to submission. Failure to complete forms/affidavits may render your bid null and void. Bids will be opened and read aloud in the Commissioners' Courtroom, Fourth Floor, 1149 Pearl Street, Beaumont, Texas.

In the event the Commissioners' Courtroom is in use at time of opening, bids will be opened in the Conference Room of the County Judge.

Hours for the Purchasing Department are 8:00 am – 5:00 pm central time, Monday - Friday.

Bid Proposal

Cheek Community Sewer Improvements - Cheek Phase III

Jefferson County, Texas

IFB 13-006/KJS|TXCDBG Contract No. 711281|d.p. Job No. 112-29B

| NO. | ITEM | UNIT | QUANTITY | UNIT PRICE BID WRITTEN IN WORDS | | UNIT PRICE WRITTEN IN FIGURES | | TOTAL PRICE BID WRITTEN IN FIGURES | |
|-----|---|------|----------|---------------------------------|-------|-------------------------------|-------|------------------------------------|-------|
| | | | | DOLLARS | CENTS | DOLLARS | CENTS | DOLLARS | CENTS |
| 1 | MOBILIZATION AND DEMOBILIZATION | L.S. | 1 | | | | | | |
| 2 | LPSS GRINDER PUMP STATION INCLUDING PUMP, CONTROLS & HOUSING INCLUDING ELECTRICAL INSTALLATION AND 4" SEWER CONNECTION FROM HOUSE COMPLETE IN PLACE PER SUMMARY OF WORK | L.S. | 11 | | | | | | |
| 3 | CONNECT NEW 4" FORCE MAIN TO THE EXISTING LIFT STATION INCLUDING LABOR, MATERIAL AND EQUIPMENT COMPLETE IN PLACE | L.S. | 1 | | | | | | |
| 4 | 3" PVC SDR-26 SEWER FORCE MAIN COMPLETE IN PLACE INCLUDING SAND ENCASEMENT PER DETAIL | L.F. | 115 | | | | | | |
| 5 | 4" PVC SDR-26 SEWER FORCE MAIN COMPLETE IN PLACE INCLUDING SAND ENCASEMENT PER DETAIL | L.F. | 7,520 | | | | | | |
| 6 | DIRECTIONAL BORE: INCLUDING 6" HDPE DR-11 CARRIER PIPE AND TRANSITION COUPLINGS W/PIPE RESTRAINTS FOR LNVA CROSSING COMPLETE IN PLACE | L.F. | 300 | | | | | | |
| 7 | ROADWAY BORE AND STEEL CASING FOR 4" SEWER FORCE MAIN, INCLUDING END SEALS | L.F. | 195 | | | | | | |
| 8 | ROADWAY BORE AND STEEL CASING FOR 3" SEWER FORCE MAIN, ENCLUDE END SEALS | L.F. | 45 | | | | | | |

Bid Proposal

Cheek Community Sewer Improvements - Cheek Phase III

Jefferson County, Texas

IFB 13-006/KJS|TXCDBG Contract No. 711281|d.p. Job No. 112-29B

| NO. | ITEM | UNIT | QUANTITY | UNIT PRICE BID WRITTEN IN WORDS | | UNIT PRICE WRITTEN IN FIGURES | | TOTAL PRICE BID WRITTEN IN FIGURES | |
|-----|--|------|----------|---------------------------------|-------|-------------------------------|-------|------------------------------------|-------|
| | | | | DOLLARS | CENTS | DOLLARS | CENTS | DOLLARS | CENTS |
| 9 | DRIVEWAY BORE FOR 4" SEWER FORCE MAIN | L.F. | 580 | | | | | | |
| 10 | 4" 45 DEG. BEND DI-MJ, RESTRAINED W/ MEGA-LUGS | EA. | 4 | | | | | | |
| 11 | 3" 45 DEG. BEND DI-MJ, RESTRAINED W/ MEGA-LUGS | EA. | 1 | | | | | | |
| 12 | 4" GATE VALVE DI-MJ RESTRAINED W/MEGA-LUGS | EA. | 1 | | | | | | |
| 13 | 3" GATE VALVE DI-MJ RESTRAINED W/MEGA-LUGS | EA. | 1 | | | | | | |
| 14 | 4"x4" WYE DI-MJ, RESTRAINED W/MEGA-LUG | EA. | 1 | | | | | | |
| 15 | 4"x3" REDUCER DI-MJ, RESTRAINED W/MEGA-LUG | EA. | 1 | | | | | | |
| 16 | INLINE FLUSHING VALVE W/MANHOLE | EA. | 1 | | | | | | |

Bid Proposal

Cheek Community Sewer Improvements - Cheek Phase III

Jefferson County, Texas

IFB 13-006/KJS|TXCDBG Contract No. 711281|d.p. Job No. 112-29B

| NO. | ITEM | UNIT | QUANTITY | UNIT PRICE BID WRITTEN IN WORDS | | UNIT PRICE WRITTEN IN FIGURES | | TOTAL PRICE BID WRITTEN IN FIGURES | |
|-----|---|------|----------|---------------------------------|-------|-------------------------------|-------|------------------------------------|-------|
| | | | | DOLLARS | CENTS | DOLLARS | CENTS | DOLLARS | CENTS |
| 17 | 4" TERMINAL CLEANOUT W/VAULT | EA. | 1 | | | | | | |
| 18 | 3" TERMINAL CLEANOUT W/VAULT | EA. | 1 | | | | | | |
| 19 | 2" SEWER COMBINATION AIR VALVE, SINGLE BODY, W/STANDARD MANHOLE, RING AND COVER COMPLETE IN PLACE | EA. | 1 | | | | | | |
| 20 | RELOCATE MAIL BOXES AS DIRECTED IN THE FIELD | EA. | 32 | | | | | | |
| 21 | 1 1/4" HDPE SDR-11 SANITARY SEWER SERVICE LINE, COMPLETE IN PLACE, FROM VALVE BOX TO GRINDER UNIT | L.F. | 2,100 | | | | | | |
| 22 | LONG SIDE SANITARY SEWER LOW PRESSURE SERVICE LINE FROM FORCE MAIN TO AND INCLUDING VALVE BOX AT PROPERTY LINE INCLUDING TAP, 1-1/4" SDR-11 HDPE, FITTINGS, VALVES AND ROADWAY BORE COMPLETE IN PLACE | EA. | 11 | | | | | | |
| 23 | SHORT SIDE SANITARY SEWER LOW PRESSURE SERVICE LINE FROM FORCE MAIN TO AND INCLUDING VALVE BOX AT PROPERTY LINE INCLUDING TAP, 1-1/4" SDR-11 HDPE, FITTINGS AND VALVES COMPLETE IN PLACE | EA. | 1 | | | | | | |

Bid Proposal

Cheek Community Sewer Improvements - Cheek Phase III

Jefferson County, Texas

IFB 13-006/KJS|TXCDBG Contract No. 711281|d.p. Job No. 112-29B

| NO. | ITEM | UNIT | QUANTITY | UNIT PRICE BID WRITTEN IN WORDS | | UNIT PRICE WRITTEN IN FIGURES | | TOTAL PRICE BID WRITTEN IN FIGURES | |
|-----|---|------|----------|---------------------------------|-------|-------------------------------|-------|------------------------------------|-------|
| | | | | DOLLARS | CENTS | DOLLARS | CENTS | DOLLARS | CENTS |
| 24 | "610" ROCK FOR DRIVEWAYS, LOOSE DUMP AND SPREAD MIN. 6" THICK | TON | 120 | | | | | | |
| | | | | | | TOTAL | | | |
| | STATEMENT FOR SEPARATED CONTRACT COMPLIANCE: | | | | | | | | |
| | NON-CONSUMABLE MATERIALS AND EQUIPMENT..... | | | | | | | \$ | |
| | SKILLED LABOR, MATERIALS, EQUIPMENT AND TOOLS..... | | | | | | | \$ | |
| | | | | | | TOTAL | | \$ | |

The undersigned agrees to commence work within ten (10) days after the date of written notice to commence work and to substantially complete the work on which he has bid within (____) calendar days as provided in the General Conditions of the Agreement. Enclosed herewith is a cashier's check, certified check, or bid bond in the sum of 5% of the greatest amount bid which it is agreed shall be collected and retained by the **OWNER** as liquidating damages in the event this proposal is accepted by the **OWNER** within sixty (60) days after the date advertised for the reception of bids and the undersigned fails to execute the contract and the required bond with the **OWNER**, under the conditions hereof, within ten (10) days after the date said proposal is accepted, otherwise said check or bond shall be returned to the undersigned upon demand.

CONTRACTOR: _____

ADDRESS: _____

Phone: _____

BY: _____

DATE: _____

Alternate Bid Proposal

Cheek Community Sewer Improvements Project

Jefferson County, Texas

IFB 13-006/KJS|TXCDBG Contract No. 711281|d.p. Job No. 112-29B

| NO. | ITEM | UNIT | QUANTITY | UNIT PRICE BID WRITTEN IN WORDS | | UNIT PRICE WRITTEN IN FIGURES | | TOTAL PRICE BID WRITTEN IN FIGURES | |
|-----|---|------|----------|---------------------------------|-------|-------------------------------|-------|------------------------------------|-------|
| | | | | DOLLARS | CENTS | DOLLARS | CENTS | DOLLARS | CENTS |
| 1 | MOBILIZATION AND DEMOBILIZATION | L.S. | 1 | | | | | | |
| 2 | LPSS GRINDER PUMP STATION INCLUDING PUMP, CONTROLS & HOUSING INCLUDING ELECTRICAL INSTALLATION AND 4" SEWER CONNECTION FROM HOUSE COMPLETE IN PLACE PER SUMMARY OF WORK | L.S. | 11 | | | | | | |
| 3 | CONNECT NEW 6" FORCE MAIN TO THE EXISTING LIFT STATION INCLUDING LABOR, MATERIAL AND EQUIPMENT COMPLETE IN PLACE | L.S. | 1 | | | | | | |
| 4 | 3" PVC SDR-26 SEWER FORCE MAIN COMPLETE IN PLACE INCLUDING SAND ENCASEMENT PER DETAIL | L.F. | 115 | | | | | | |
| 5 | 6" PVC SDR-26 SEWER FORCE MAIN COMPLETE IN PLACE INCLUDING SAND ENCASEMENT PER DETAIL | L.F. | 7,520 | | | | | | |
| 6 | DIRECTIONAL BORE: INCLUDING 6" HDPE DR-11 CARRIER PIPE AND TRANSITION COUPLINGS W/PIPE RESTRAINTS FOR LNVA CROSSING COMPLETE IN PLACE | L.F. | 300 | | | | | | |
| 7 | ROADWAY BORE AND STEEL CASING FOR 6" SEWER FORCE MAIN INCLUDING END SEALS | L.F. | 195 | | | | | | |
| 8 | ROADWAY BORE AND STEEL CASING FOR 3" SEWER FORCE MAIN INCLUDING END SEALS | L.F. | 45 | | | | | | |

Alternate Bid Proposal

Cheek Community Sewer Improvements Project

Jefferson County, Texas

IFB 13-006/KJS|TXCDBG Contract No. 711281|d.p. Job No. 112-29B

| NO. | ITEM | UNIT | QUANTITY | UNIT PRICE BID WRITTEN IN WORDS | | UNIT PRICE WRITTEN IN FIGURES | | TOTAL PRICE BID WRITTEN IN FIGURES | |
|-----|--|------|----------|---------------------------------|-------|-------------------------------|-------|------------------------------------|-------|
| | | | | DOLLARS | CENTS | DOLLARS | CENTS | DOLLARS | CENTS |
| 9 | DRIVEWAY BORE FOR 6" SEWER FORCE MAIN | L.F. | 580 | | | | | | |
| 10 | 6" 45 DEG. BEND DI-MJ, RESTRAINED W/ MEGA-LUGS | EA. | 4 | | | | | | |
| 11 | 3" 45 DEG. BEND DI-MJ, RESTRAINED W/ MEGA-LUGS | EA. | 1 | | | | | | |
| 12 | 6" GATE VALVE DI-MJ RESTRAINED W/MEGA-LUGS | EA. | 1 | | | | | | |
| 13 | 3" GATE VALVE DI-MJ RESTRAINED W/MEGA-LUGS | EA. | 1 | | | | | | |
| 14 | 6"x6" WYE DI-MJ, RESTRAINED W/MEGA-LUG | EA. | 1 | | | | | | |
| 15 | 6"x3" REDUCER DI-MJ, RESTRAINED W/MEGA-LUG | EA. | 1 | | | | | | |
| 16 | INLINE FLUSHING VALVE W/MANHOLE | EA. | 1 | | | | | | |

Alternate Bid Proposal

Cheek Community Sewer Improvements Project

Jefferson County, Texas

IFB 13-006/KJS|TXCDBG Contract No. 711281|d.p. Job No. 112-29B

| NO. | ITEM | UNIT | QUANTITY | UNIT PRICE BID WRITTEN IN WORDS | | UNIT PRICE WRITTEN IN FIGURES | | TOTAL PRICE BID WRITTEN IN FIGURES | |
|-----|---|------|----------|---------------------------------|-------|-------------------------------|-------|------------------------------------|-------|
| | | | | DOLLARS | CENTS | DOLLARS | CENTS | DOLLARS | CENTS |
| 17 | 6" TERMINAL CLEANOUT W/VAULT | EA. | 1 | | | | | | |
| 18 | 3" TERMINAL CLEANOUT W/VAULT | EA. | 1 | | | | | | |
| 19 | 2" SEWER COMBINATION AIR VALVE, SINGLE BODY, W/STANDARD MANHOLE, RING AND COVER COMPLETE IN PLACE | EA. | 1 | | | | | | |
| 20 | RELOCATE MAIL BOXES AS DIRECTED IN THE FIELD | EA. | 32 | | | | | | |
| 21 | 1 1/4" HDPE SDR-11 SANITARY SEWER SERVICE LINE, COMPLETE IN PLACE, FROM VALVE BOX TO GRINDER UNIT | L.F. | 2,100 | | | | | | |
| 22 | LONG SIDE SANITARY SEWER LOW PRESSURE SERVICE LINE FROM FORCE MAIN TO AND INCLUDING VALVE BOX AT PROPERTY LINE INCLUDING TAP, 1-1/4" SDR-11 HDPE, FITTINGS, VALVES AND ROADWAY BORE COMPLETE IN PLACE | EA. | 11 | | | | | | |
| 23 | SHORT SIDE SANITARY SEWER LOW PRESSURE SERVICE LINE FROM FORCE MAIN TO AND INCLUDING VALVE BOX AT PROPERTY LINE INCLUDING TAP, 1-1/4" SDR-11 HDPE, FITTINGS AND VALVES COMPLETE IN PLACE | EA. | 1 | | | | | | |

Alternate Bid Proposal

Cheek Community Sewer Improvements Project

Jefferson County, Texas

IFB 13-006/KJS|TXCDBG Contract No. 711281|d.p. Job No. 112-29B

| NO. | ITEM | UNIT | QUANTITY | UNIT PRICE BID WRITTEN IN WORDS | | UNIT PRICE WRITTEN IN FIGURES | | TOTAL PRICE BID WRITTEN IN FIGURES | |
|-----|---|------|----------|---------------------------------|-------|-------------------------------|-------|------------------------------------|-------|
| | | | | DOLLARS | CENTS | DOLLARS | CENTS | DOLLARS | CENTS |
| 24 | "610" ROCK FOR DRIVEWAYS, LOOSE DUMP AND SPREAD MIN. 6" THICK | TON | 120 | | | | | | |
| | | | | | | TOTAL | | | |
| | STATEMENT FOR SEPARATED CONTRACT COMPLIANCE: | | | | | | | | |
| | NON-CONSUMABLE MATERIALS AND EQUIPMENT..... | | | | | | | \$ | |
| | SKILLED LABOR, MATERIALS, EQUIPMENT AND TOOLS..... | | | | | | | \$ | |
| | | | | | | TOTAL | | \$ | |

The undersigned agrees to commence work within ten (10) days after the date of written notice to commence work and to substantially complete the work on which he has bid within (____) calendar days as provided in the General Conditions of the Agreement. Enclosed herewith is a cashier's check, certified check, or bid bond in the sum of 5% of the greatest amount bid which it is agreed shall be collected and retained by the **OWNER** as liquidating damages in the event this proposal is accepted by the **OWNER** within sixty (60) days after the date advertised for the reception of bids and the undersigned fails to execute the contract and the required bond with the **OWNER**, under the conditions hereof, within ten (10) days after the date said proposal is accepted, otherwise said check or bond shall be returned to the undersigned upon demand.

CONTRACTOR: _____

ADDRESS: _____

Phone: _____

BY: _____

DATE: _____

Supplemental Items Proposal

Cheek Community Sewer Improvements Project

Jefferson County, Texas

IFB 13-006/KJS|TXCDBG Contract No. 711281|d.p. Job No. 112-29B

| NO. | ITEM | UNIT | QUANTITY | UNIT PRICE BID WRITTEN IN WORDS | | UNIT PRICE WRITTEN IN FIGURES | | TOTAL PRICE BID WRITTEN IN FIGURES | |
|-----|--|------|----------|---------------------------------|-------|-------------------------------|-------|------------------------------------|-------|
| | | | | DOLLARS | CENTS | DOLLARS | CENTS | DOLLARS | CENTS |
| 1 | MANHOURS WHEN AUTHORIZED BY THE ENGINEER | HOUR | 10 | | | | | | |
| 2 | TRUCK HOURS WHEN AUTHORIZED BY THE ENGINEER | HOUR | 10 | | | | | | |
| 3 | BACK HOE / LOADER HOUR WHEN AUTHORIZED BY THE ENGINEER | HOUR | 10 | | | | | | |
| 4 | CEMENT STABILIZED SAND BACKFILL 1-1/2 SACK/C.Y. WHEN AUTHORIZED BY THE ENGINEER | TON | 10 | | | | | | |
| 5 | EXTRA CLASS-A CONCRETE - BULK, COMPLETE IN PLACE WHEN AUTHORIZED BY THE ENGINEER | C.Y. | 10 | | | | | | |
| 6 | EXTRA CLASS-A CONCRETE - FORMED, COMPLETE IN PLACE WHEN AUTHORIZED BY THE ENGINEER | C.Y. | 10 | | | | | | |
| 7 | REINFORCING STEEL WHEN AUTHORIZED BY THE ENGINEER | LB. | 200 | | | | | | |
| 8 | 15" RCP C-76 CULVERT INSTALLED ON-GRADE WHEN AUTHORIZED BY THE ENGINEER | L.F. | 30 | | | | | | |
| 9 | 18" RCP C-76 CULVERT INSTALLED ON-GRADE WHEN AUTHORIZED BY THE ENGINEER | L.F. | 30 | | | | | | |

Supplemental Items Proposal

Cheek Community Sewer Improvements Project

Jefferson County, Texas

IFB 13-006/KJS|TXCDBG Contract No. 711281|d.p. Job No. 112-29B

| NO. | ITEM | UNIT | QUANTITY | UNIT PRICE BID WRITTEN IN WORDS | | UNIT PRICE WRITTEN IN FIGURES | | TOTAL PRICE BID WRITTEN IN FIGURES | |
|-----|---|------|----------|---------------------------------|-------|-------------------------------|-------|------------------------------------|-------|
| | | | | DOLLARS | CENTS | DOLLARS | CENTS | DOLLARS | CENTS |
| 10 | 2" PVC, SDR-26 SEWER FORCE MAIN COMPLETE IN PLACE, INCLUDING SAND ENCASEMENT PER DETAIL | L.F. | 600 | | | | | | |
| 11 | ROADWAY BORE AND STEEL CASING FOR 2" SEWER FORCE MAIN, INCLUDING END SEALS | L.F. | 40 | | | | | | |
| 12 | TIE-IN 2" FORCE MAIN TO MAINLINE FORCE MAIN, COMPLETE IN PLACE | EA. | 1 | | | | | | |
| 13 | 2" TERMINAL CLEANOUT W/VAULT PER DETAIL | EA. | 1 | | | | | | |
| 14 | 2" GATE VALVE DI-MJ RESTRAINED W/MEGA-LUG | EA. | 1 | | | | | | |

NOTE: "SUPPLEMENTAL ITEMS" PROPOSAL ARE FOR USE WHEN DIRECTED BY THE ENGINEER. SUPPLEMENTAL ITEMS ARE NOT TO BE CONSIDERED AS A PART OF THE BID TOTAL, WHEN REQUIRED FOR USE THESE ITEMS MUST BE CHANGE ORDERED INTO THE CONTRACT.



CHEEK COMMUNITY SEWER IMPROVEMENT PROJECT
 PHASE III
 JEFFERSON COUNTY, TEXAS

PLAN
 STA 69+00 TO STA 79+00

| | |
|------------|-----------|
| DATE | APR, 2013 |
| JOB NUMBER | 112-29B |
| SCALE | 1" = 40' |
| DRAWN BY | RJC |
| CHECKED BY | WVL |
| SHEET | 9 |
| OF | 13 |

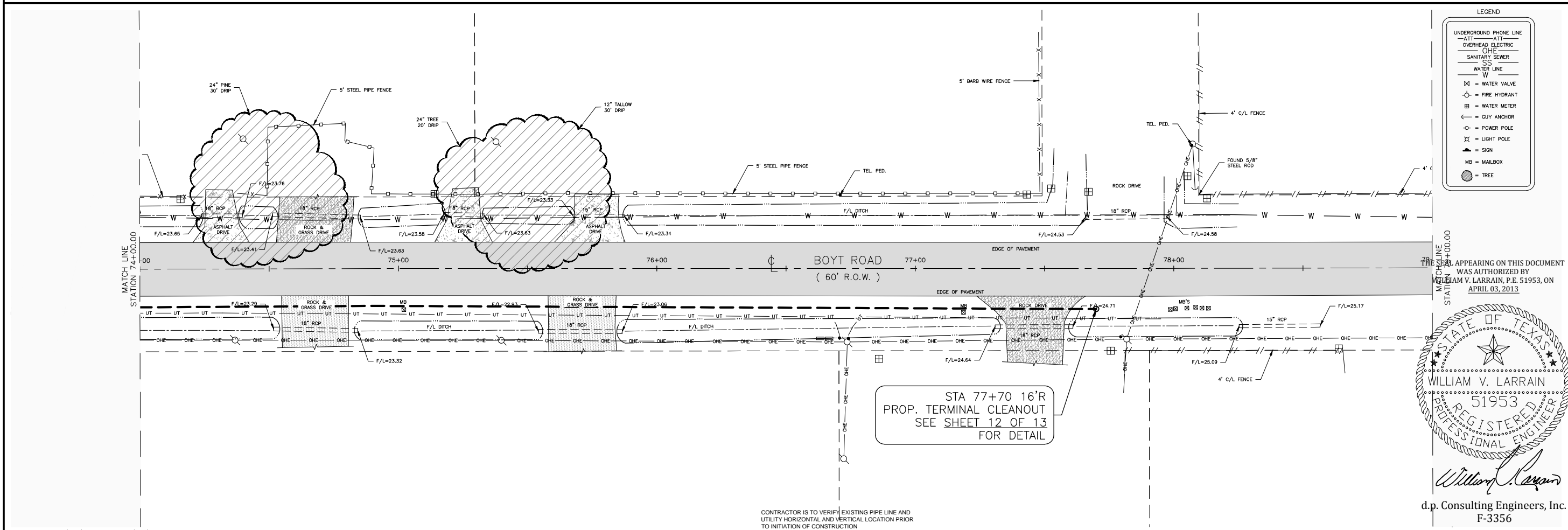
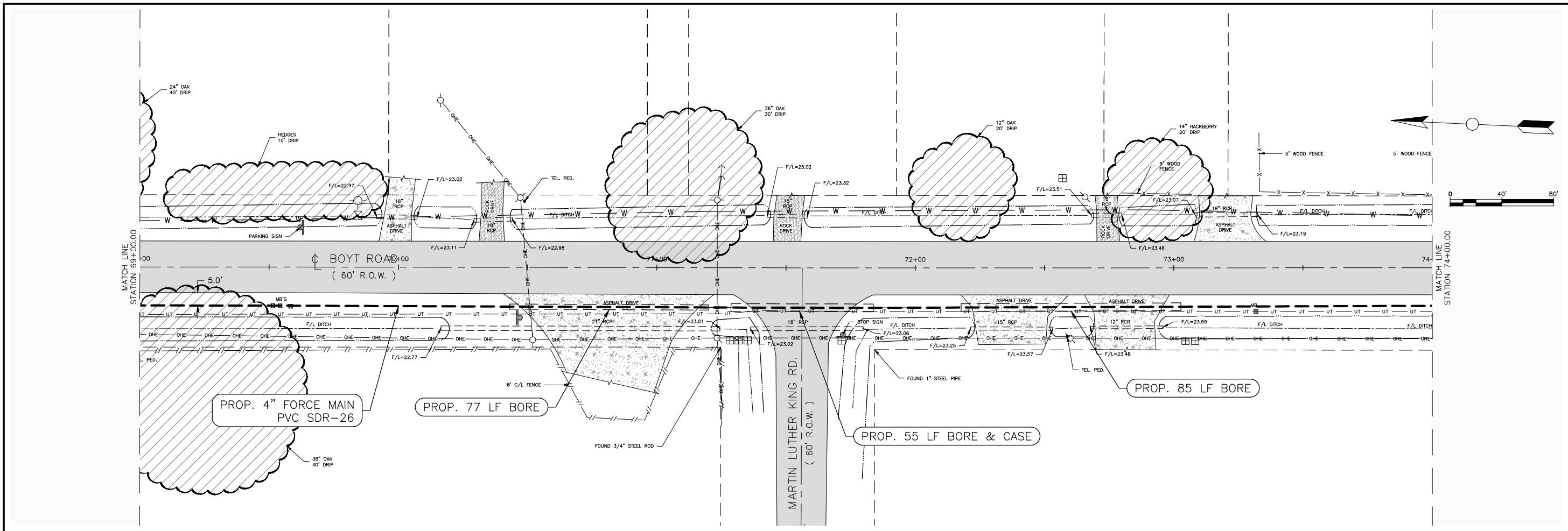

LEGEND

| | |
|---|------------------------|
| — | UNDERGROUND PHONE LINE |
| — | ATT |
| — | OVERHEAD ELECTRIC |
| — | OHE |
| — | SANITARY SEWER |
| — | SS |
| — | WATER LINE |
| — | W |
| ⊗ | WATER VALVE |
| ⊙ | FIRE HYDRANT |
| ⊕ | WATER METER |
| ⊖ | GUY ANCHOR |
| ⊘ | POWER POLE |
| ⊙ | LIGHT POLE |
| ⊙ | SIGN |
| ⊙ | MB |
| ⊙ | MAILBOX |
| ● | TREE |

APPEARING ON THIS DOCUMENT
 WAS AUTHORIZED BY
 WILLIAM V. LARRAIN, P.E. 51953, ON
 APRIL 03, 2013

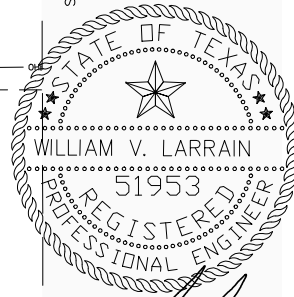

William V. Larrain
 d.p. Consulting Engineers, Inc.
 F-3356

STA 77+70 16'R
 PROP. TERMINAL CLEANOUT
 SEE SHEET 12 OF 13
 FOR DETAIL

CONTRACTOR IS TO VERIFY EXISTING PIPE LINE AND UTILITY HORIZONTAL AND VERTICAL LOCATION PRIOR TO INITIATION OF CONSTRUCTION

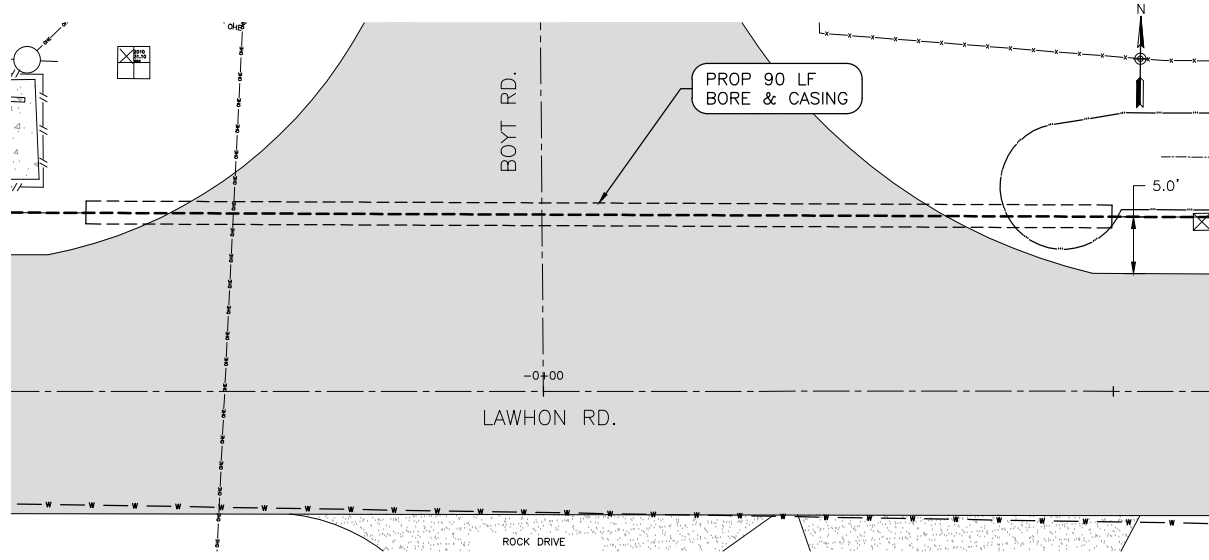

PLAN VIEW

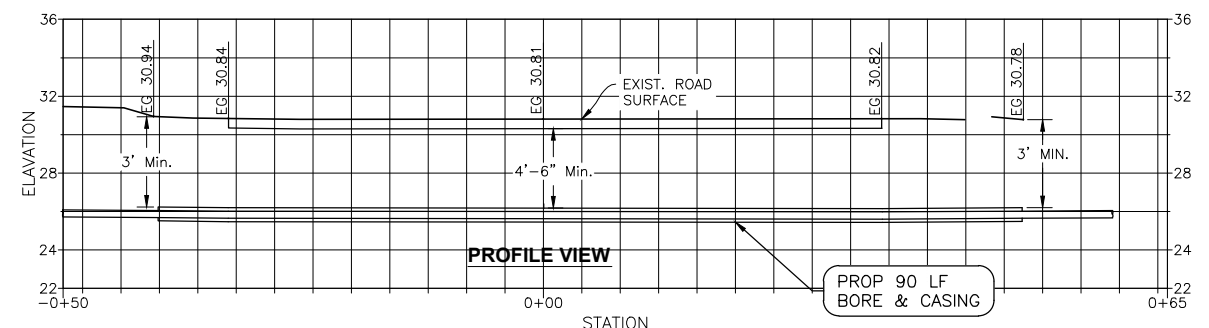

PROFILE VIEW
LPSS FORCE MAIN CROSSING
BOYT ROAD & LAWHON INTERSECTION

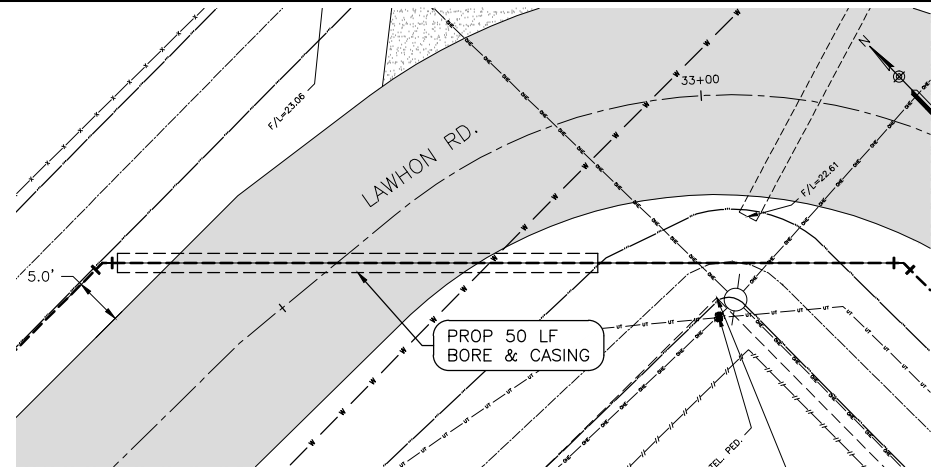

PLAN VIEW

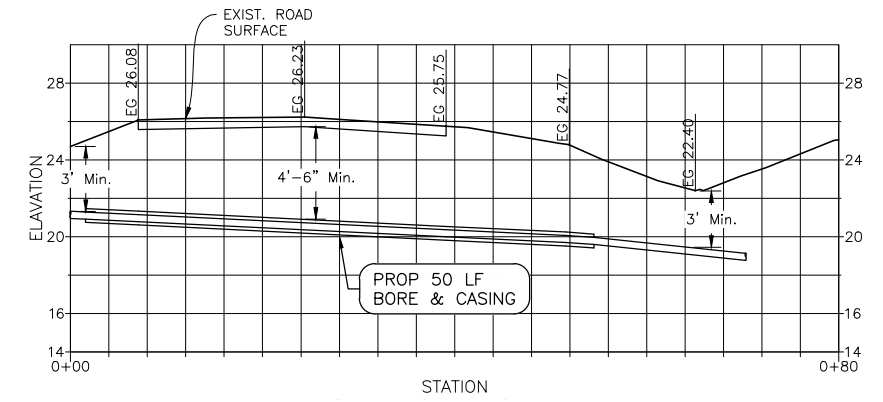

PROFILE VIEW
LPSS FORCE MAIN CROSSING
BOYT ROAD

LEGEND

- UNDERGROUND PHONE LINE
- OVERHEAD ELECTRIC
- SANITARY SEWER
- WATER LINE
- ⊗ WATER VALVE
- ⊕ FIRE HYDRANT
- ⊞ WATER METER
- GUY ANCHOR
- ⊖ POWER POLE
- ⊗ LIGHT POLE
- ⊞ SIGN
- ⊞ MB MAILBOX
- TREE

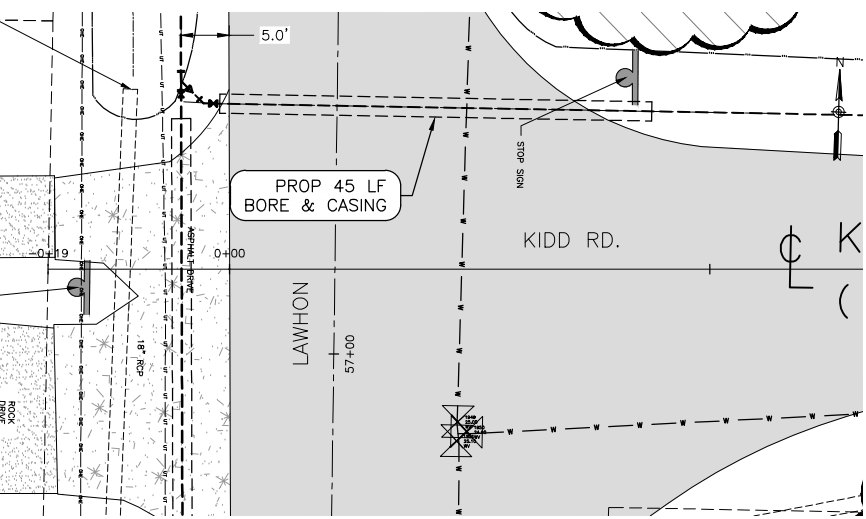

PLAN VIEW

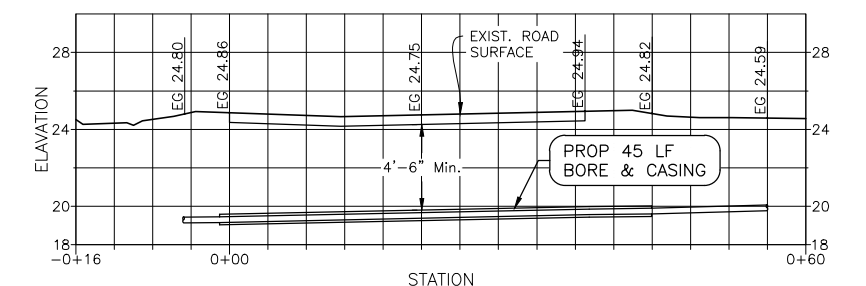

PROFILE VIEW
LPSS FORCE MAIN CROSSING
LAWHON & KIDD RD. INTERSECTION

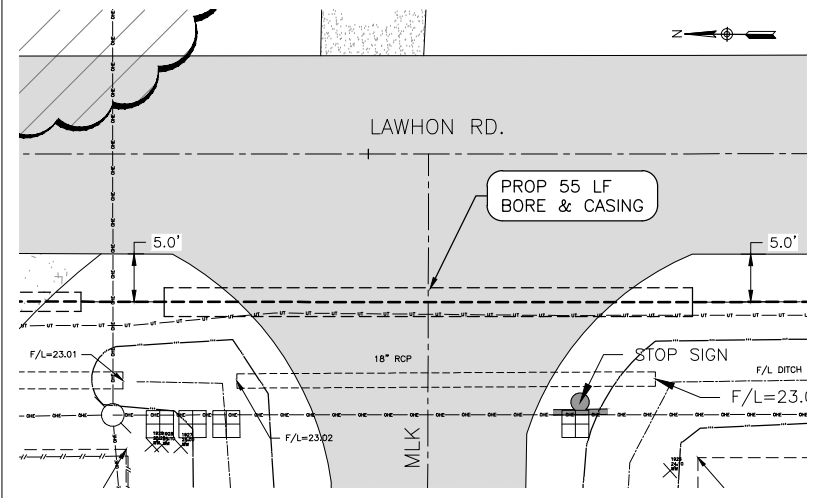

PLAN VIEW

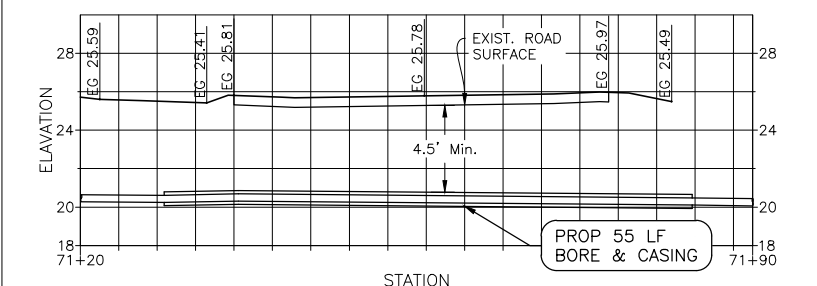

PROFILE VIEW
LPSS FORCE MAIN CROSSING
LAWHON & MLK INTERSECTION

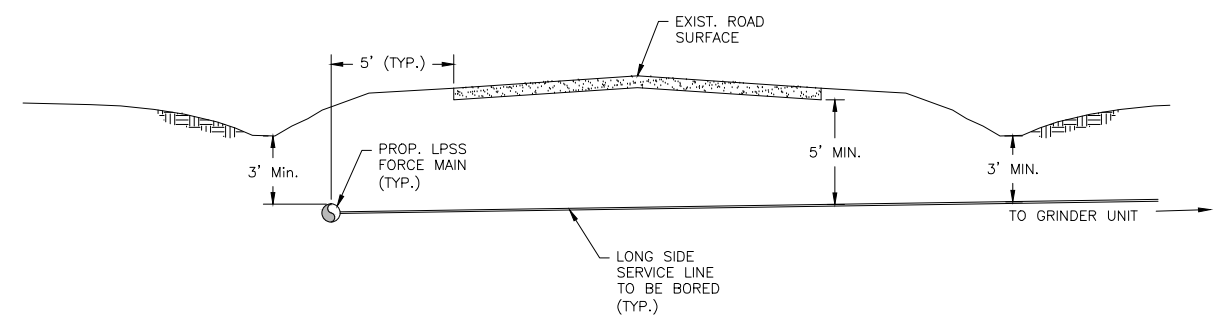

INSTALLATION DETAIL FOR
LONG SIDE SERVICES
CROSSING COUNTY ROADS
(TYPICAL)

THE SEAL APPEARING ON THIS DOCUMENT
WAS AUTHORIZED BY
WILLIAM V. LARRAIN, P.E. 51953, ON
APRIL 03, 2013.



William V. Larrain
d.p. Consulting Engineers, Inc.
F-3356

d.p. CONSULTING ENGINEERS, INC.
 3727 DOCTORS DRIVE
 P.O. DRAWER 2110
 PORT ARTHUR, TX 77642
 PHONE (409) 983-6263
 FAX (409) 983-6265
 dped@engineersinc.com

CHEEK COMMUNITY SEWER IMPROVEMENT PROJECT
 PHASE III
 JEFFERSON COUNTY, TEXAS

PLAN & PROFILE
 ROADWAY BORES

| | |
|------------|--------------------------|
| DATE | MAR 2013 |
| JOB NUMBER | 112-29B |
| SCALE | 1" = 20' H 1" = 10' V |
| DRAWN BY | RJC |
| CHECKED BY | WWL |
| SHEET | 9A |
| OF | 13 |

Apr 22, 2013 - 11:00am Z:\Cheek\112-29B Phase III LPSS\Plan\Roadway Bore&Case.dwg

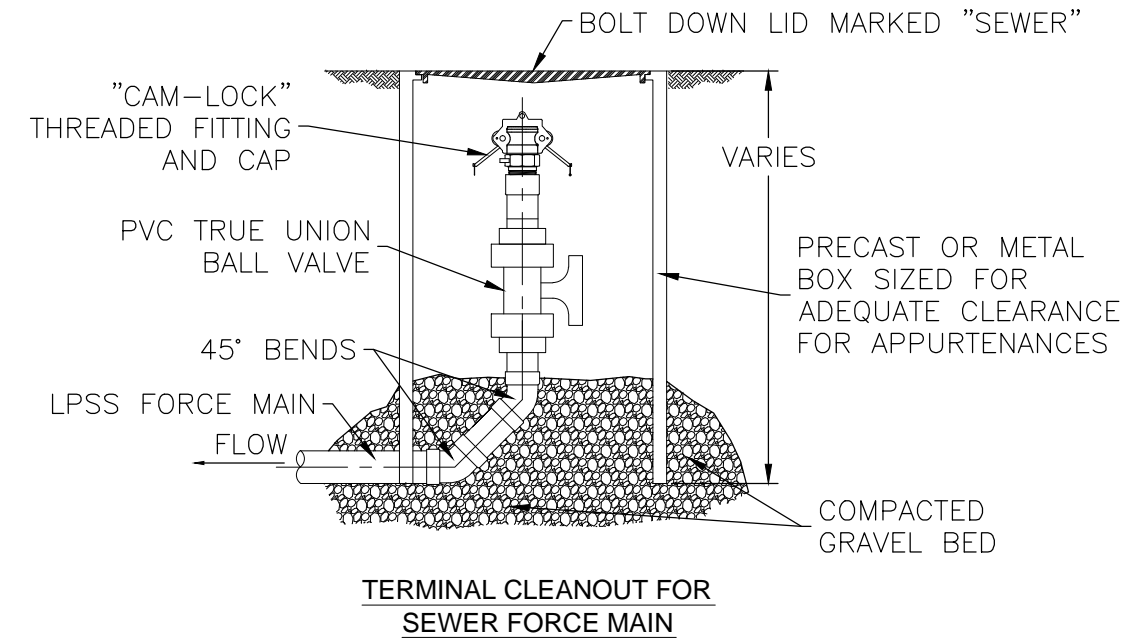
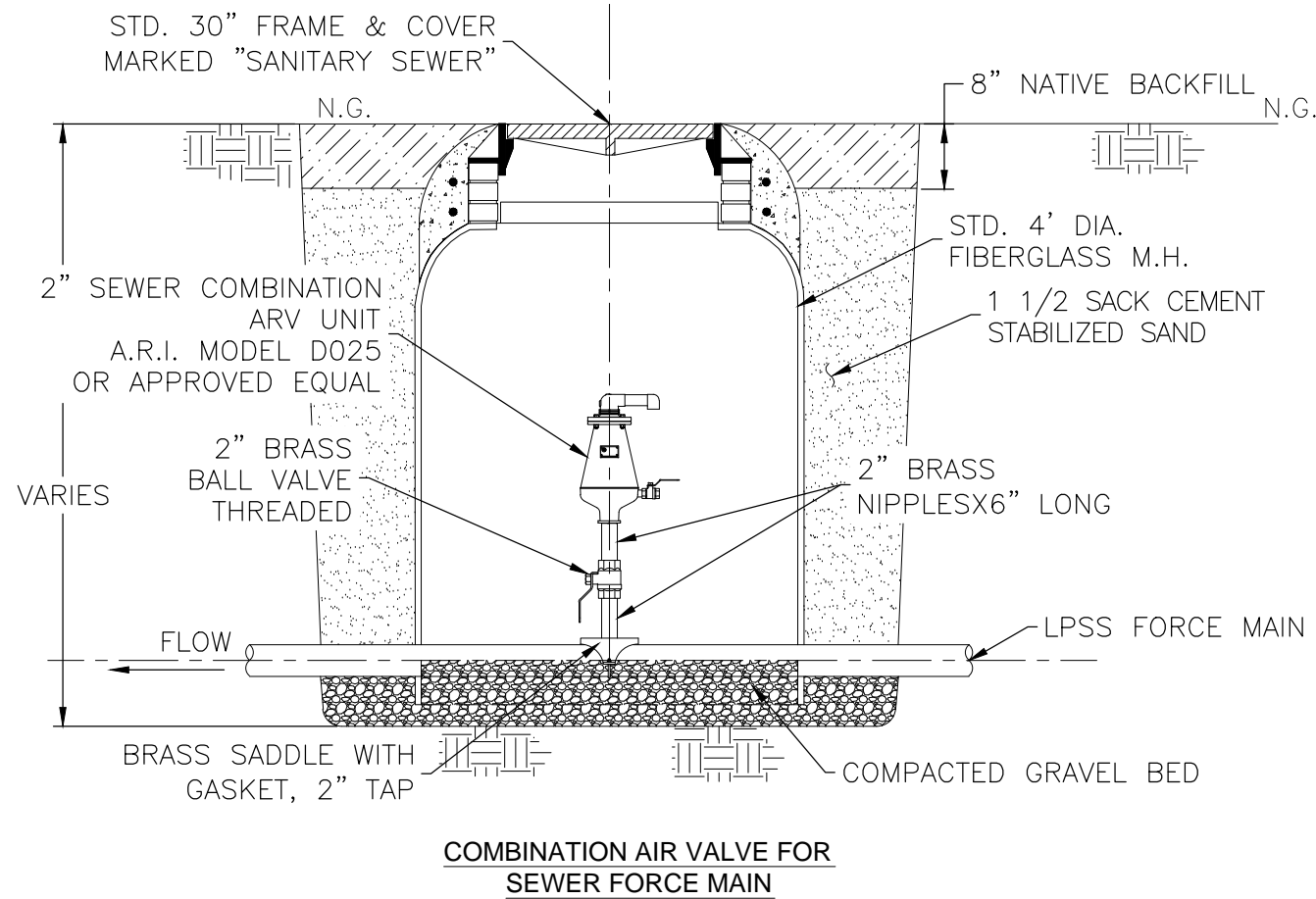

- NOTE:
- PVC FITTINGS SHALL BE OF THE SAME SIZE AND SPECIFICATIONS OF PROPOSED FORCE MAIN.
 - PVC FITTINGS SHALL BE SOLVENT WELD.

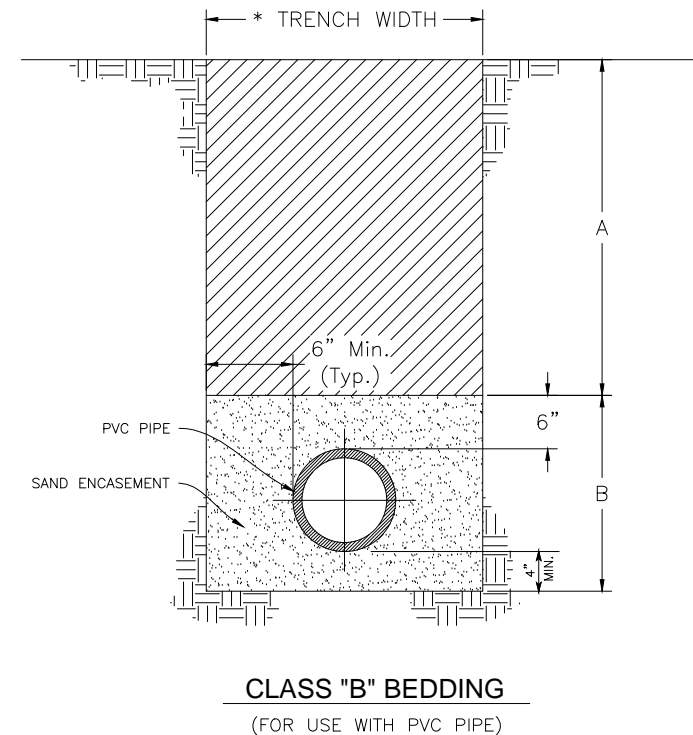
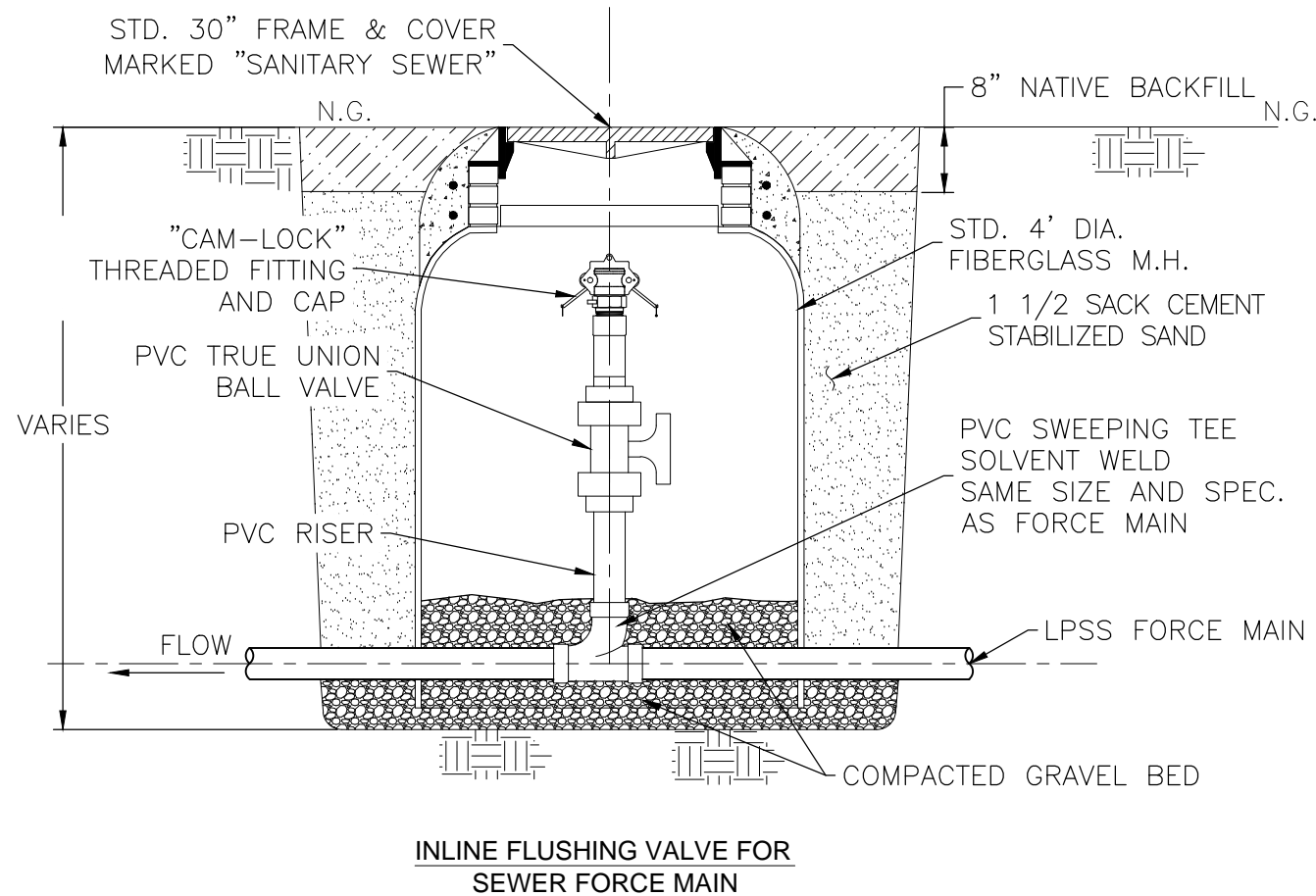

- NOTES
- A - NATIVE BACKFILL IN ACCORDANCE WITH SEWER CONSTRUCTION SPECIFICATIONS
- B - BACKFILL WITH FIRMLY TAMPED SAND
- * PIPE LESS THAN 30-INCH
MAX. 1'-6"+ ϕ
MIN. 1'-0"+ ϕ
PIPE 30-INCH AND LARGER
MAX. 2'-0"+ ϕ
MIN. 1'-4"+ ϕ

THE SEAL APPEARING ON THIS DOCUMENT WAS AUTHORIZED BY WILLIAM V. LARRAIN, P.E. 51953, ON APRIL 03, 2013

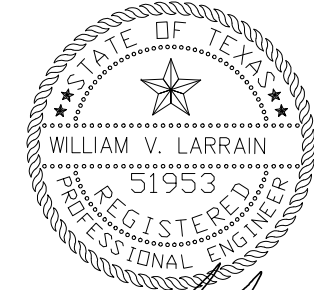

William V. Larrain
d.p. Consulting Engineers, Inc.
F-3356

Cheek Community Sewer Improvements Project

Jefferson County, Texas

IFB 13-006/KJS|TXCDBG Contract No. 711281|d.p. Job No. 112-29B

LIST OF ADDRESSES FOR GRINDER UNIT INSTALLATIONS

| NO. | ADDRESSES | REMARKS |
|-----|--------------------------------------|---------|
| 1 | 7955 Boyt Road, Beaumont, TX 77713 | |
| 2 | 7293 Boyt Road, Beaumont, TX 77713 | |
| 3 | 7187 Boyt Road, Beaumont, TX 77713 | |
| 4 | 7391 Boyt Road, Beaumont, TX 77713 | |
| 5 | 6574 Boyt Road, Beaumont, TX 77713 | |
| 6 | 7257 Boyt Road, Beaumont, TX 77713 | |
| 7 | 6852 Boyt Road, Beaumont, TX 77713 | |
| 8 | 6608 Boyt Road, Beaumont, TX 77713 | |
| 9 | 9833 Lawhon Road, Beaumont, TX 77713 | |
| 10 | 7231 Boyt Road, Beaumont, TX 77713 | |
| 11 | 7369 Boyt Road, Beaumont, TX 77713 | |

General Decision Number: TX130079 04/05/2013 TX79

Superseded General Decision Number: TX20120079

State: Texas

Construction Type: Heavy

Counties: Hardin, Jefferson and Orange Counties in Texas.

HEAVY CONSTRUCTION PROJECTS (Including Water and Sewer Lines and Excluding Industrial and Processing Plants, and Refineries)

| | |
|---------------------|------------------|
| Modification Number | Publication Date |
| 0 | 01/04/2013 |
| 1 | 04/05/2013 |

* ELEC0479-003 12/31/2012

| | Rates | Fringes |
|-------------------------|----------|---------|
| ELECTRICIAN..... | \$ 26.00 | 11.42 |
| ----- | | |
| SUTX2000-002 02/11/2000 | | |

| | Rates | Fringes |
|------------------------------|----------|---------|
| Carpenters: | | |
| Form Building/Form Setting.. | \$ 13.15 | |
| All Other Work..... | \$ 13.56 | |
| Concrete Finisher..... | \$ 13.50 | |
| Laborers: | | |
| Common..... | \$ 7.41 | |
| Pipelayer..... | \$ 8.29 | |
| Painters: | | |
| Spray and Brush..... | \$ 12.07 | |
| PILEDRIVERMAN..... | \$ 13.65 | |
| PLUMBER..... | \$ 18.28 | 4.69 |
| Power equipment operators: | | |
| Backhoe..... | \$ 15.55 | 1.89 |
| Bulldozer..... | \$ 15.00 | |
| Crane..... | \$ 13.77 | |
| Front End Loader..... | \$ 10.63 | |
| Trackhoe..... | \$ 15.60 | |
| Truck drivers: | | |
| Dump..... | \$ 10.00 | |
| ----- | | |

WELDERS - Receive rate prescribed for craft performing operation to which welding is incidental.

=====

Unlisted classifications needed for work not included within the scope of the classifications listed may be added after award only as provided in the labor standards contract clauses (29CFR 5.5 (a) (1) (ii)).

The body of each wage determination lists the classification and wage rates that have been found to be prevailing for the cited type(s) of construction in the area covered by the wage determination. The classifications are listed in alphabetical order of "identifiers" that indicate whether the particular rate is union or non-union.

Union Identifiers

An identifier enclosed in dotted lines beginning with characters other than "SU" denotes that the union classification and rate have found to be prevailing for that classification. Example: PLUM0198-005 07/01/2011. The first four letters , PLUM, indicate the international union and the four-digit number, 0198, that follows indicates the local union number or district council number where applicable , i.e., Plumbers Local 0198. The next number, 005 in the example, is an internal number used in processing the wage determination. The date, 07/01/2011, following these characters is the effective date of the most current negotiated rate/collective bargaining agreement which would be July 1, 2011 in the above example.

Union prevailing wage rates will be updated to reflect any changes in the collective bargaining agreements governing the rates.

0000/9999: weighted union wage rates will be published annually each January.

Non-Union Identifiers

Classifications listed under an "SU" identifier were derived from survey data by computing average rates and are not union rates; however, the data used in computing these rates may include both union and non-union data. Example: SULA2004-007 5/13/2010. SU indicates the rates are not union majority rates, LA indicates the State of Louisiana; 2004 is the year of the survey; and 007 is an internal number used in producing the

wage determination. A 1993 or later date, 5/13/2010, indicates the classifications and rates under that identifier were issued as a General Wage Determination on that date.

Survey wage rates will remain in effect and will not change until a new survey is conducted.

WAGE DETERMINATION APPEALS PROCESS

1.) Has there been an initial decision in the matter? This can be:

- * an existing published wage determination
- * a survey underlying a wage determination
- * a Wage and Hour Division letter setting forth a position on a wage determination matter
- * a conformance (additional classification and rate) ruling

On survey related matters, initial contact, including requests for summaries of surveys, should be with the Wage and Hour Regional Office for the area in which the survey was conducted because those Regional Offices have responsibility for the Davis-Bacon survey program. If the response from this initial contact is not satisfactory, then the process described in 2.) and 3.) should be followed.

With regard to any other matter not yet ripe for the formal process described here, initial contact should be with the Branch of Construction Wage Determinations. Write to:

Branch of Construction Wage Determinations
Wage and Hour Division
U.S. Department of Labor
200 Constitution Avenue, N.W.
Washington, DC 20210

2.) If the answer to the question in 1.) is yes, then an interested party (those affected by the action) can request review and reconsideration from the Wage and Hour Administrator (See 29 CFR Part 1.8 and 29 CFR Part 7). Write to:

Wage and Hour Administrator
U.S. Department of Labor
200 Constitution Avenue, N.W.
Washington, DC 20210

The request should be accompanied by a full statement of the interested party's position and by any information (wage payment data, project description, area practice material, etc.) that the requestor considers relevant to the issue.

3.) If the decision of the Administrator is not favorable, an interested party may appeal directly to the Administrative Review Board (formerly the Wage Appeals Board). Write to:

Administrative Review Board
U.S. Department of Labor
200 Constitution Avenue, N.W.
Washington, DC 20210

4.) All decisions by the Administrative Review Board are final.

=====

END OF GENERAL DECISION